

# *Grizzly* **Industrial, Inc.**®

## **MODEL G0460/G0461 12" SLIDING TABLE SAW OWNER'S MANUAL**



COPYRIGHT © JANUARY, 2007 BY GRIZZLY INDUSTRIAL, INC.  
**WARNING: NO PORTION OF THIS MANUAL MAY BE REPRODUCED IN ANY SHAPE  
OR FORM WITHOUT THE WRITTEN APPROVAL OF GRIZZLY INDUSTRIAL, INC.**

#TR8129 PRINTED IN TAIWAN



## **WARNING!**

**This manual provides critical safety instructions on the proper setup, operation, maintenance and service of this machine/equipment.**

**Failure to read, understand and follow the instructions given in this manual may result in serious personal injury, including amputation, electrocution or death.**

**The owner of this machine/equipment is solely responsible for its safe use. This responsibility includes but is not limited to proper installation in a safe environment, personnel training and usage authorization, proper inspection and maintenance, manual availability and comprehension, application of safety devices, blade/cutter integrity, and the usage of personal protective equipment.**

**The manufacturer will not be held liable for injury or property damage from negligence, improper training, machine modifications or misuse.**



## **WARNING!**

**Some dust created by power sanding, sawing, grinding, drilling, and other construction activities contains chemicals known to the State of California to cause cancer, birth defects or other reproductive harm. Some examples of these chemicals are:**

- **Lead from lead-based paints.**
- **Crystalline silica from bricks, cement and other masonry products.**
- **Arsenic and chromium from chemically-treated lumber.**

**Your risk from these exposures varies, depending on how often you do this type of work. To reduce your exposure to these chemicals: Work in a well ventilated area, and work with approved safety equipment, such as those dust masks that are specially designed to filter out microscopic particles.**

# Table of Contents

<b>INTRODUCTION</b> .....	<b>2</b>	<b>SECTION 4: OPERATIONS</b> .....	<b>32</b>
Foreword.....	2	Operation Safety .....	32
Contact Info .....	2	Operation Tips .....	32
Machine Data Sheet .....	3	Changing Blades .....	33
Machine Data Sheet .....	3	Rip Cutting .....	34
Identification.....	5	Crosscutting .....	36
<b>SECTION 1: SAFETY</b> .....	<b>7</b>	Miter Cutting .....	38
Safety Instructions for Machinery .....	7	<b>SECTION 5: ACCESSORIES</b> .....	<b>39</b>
Safety Instructions for Sliding Table Saws ....	9	<b>SECTION 6: MAINTENANCE</b> .....	<b>41</b>
Preventing Kickback .....	10	Schedule .....	41
Protecting Yourself from Kickback.....	10	Cleaning.....	41
Glossary of Terms .....	11	Unpainted Cast Iron.....	41
<b>SECTION 2: CIRCUIT REQUIREMENTS</b> .....	<b>12</b>	Lubrication .....	42
Rewiring to 440V .....	13	<b>SECTION 7: SERVICE</b> .....	<b>43</b>
<b>SECTION 3: SETUP</b> .....	<b>15</b>	Troubleshooting .....	43
Setup Safety .....	15	Replacing Belts .....	45
Unpacking .....	15	Blade Tilt.....	46
Items Needed for Setup.....	15	Squaring Crosscut Fence to Blade.....	47
Clean Up.....	16	Sliding Table Parallelism .....	48
Inventory .....	16	G0460 Electrical Components .....	49
Hardware Recognition Chart .....	18	G0460 Wiring Diagram .....	50
Site Considerations.....	19	G0461 Electrical Components .....	51
Moving & Placing Base Unit .....	19	G0461 Wiring Diagram at 220V.....	52
Mounting to Shop Floor .....	20	G0461 Wiring Diagram at 440V.....	53
Extension Tables .....	21	<b>SECTION 8: PARTS</b> .....	<b>54</b>
Main Blade.....	22	Main Body.....	54
Rip Fence and Scale .....	23	Extension Tables .....	56
Riving Knife.....	25	Sliding Table .....	57
Scoring Blade .....	27	Crosscut Table.....	59
Aligning Blades .....	28	Crosscut Fence.....	61
Crosscut Table.....	28	Rip Fence .....	62
Crosscut Fence.....	29	Tilt Assembly .....	63
Fence Scale Alignment.....	30	Motor Assembly .....	64
Dust Collection.....	30	Arbor Assembly .....	65
Test Run .....	31	<b>WARRANTY AND RETURNS</b> .....	<b>66</b>

# INTRODUCTION

---

---

## Foreword

---

---

We are proud to offer the Model G0460/G0461 12" Sliding Table Saw. This machine is part of a growing Grizzly family of fine woodworking machinery. When used according to the guidelines set forth in this manual, you can expect years of trouble-free, enjoyable operation and proof of Grizzly's commitment to customer satisfaction.

We are pleased to provide this manual with the Model G0460/G0461. It was written to guide you through assembly, review safety considerations, and cover general operating procedures. It represents our effort to produce the best documentation possible.

The specifications, drawings, and photographs illustrated in this manual represent the Model G0460/G0461 as supplied when the manual was prepared. However, owing to Grizzly's policy of continuous improvement, changes may be made at any time with no obligation on the part of Grizzly. For your convenience, we always keep current Grizzly manuals available on our website at **www.grizzly.com**. Any updates to your machine will be reflected in these manuals as soon as they are complete. Visit our site often to check for the latest updates to this manual!

## Contact Info

---

---

If you have any comments regarding this manual, please write to us at the address below:

Grizzly Industrial, Inc.  
c/o Technical Documentation Manager  
P.O. Box 2069  
Bellingham, WA 98227-2069  
Email: manuals@grizzly.com

We stand behind our machines. If you have any service questions or parts requests, please call or write us at the location listed below.

Grizzly Industrial, Inc.  
1203 Lycoming Mall Circle  
Muncy, PA 17756  
Phone: (570) 546-9663  
Fax: (800) 438-5901  
E-Mail: techsupport@grizzly.com  
Web Site: <http://www.grizzly.com>





# MACHINE DATA SHEET

Customer Service #: (570) 546-9663 • To Order Call: (800) 523-4777 • Fax #: (800) 438-5901

## MODEL G0460/G0461 12" SLIDING TABLE SAW

### Overall Dimensions:

Overall Size (with Cross Slide Fence and Sliding Table Extended)	132" W x 136" D x 48" H
Table Height	36"
Table Size (w/Extension Wings)	65" W x 59" D
Sliding Table Size	13¾" W x 59" D
Machine Net Weight	885 lbs.
Machine Shipping Weight	1163 lbs.
Crate Size	70½" W x 42" D x 44½" H
Base Footprint (w/Extension Leg)	45" W x 73" L

### Capacities:

Main Blade Diameter	12" (305mm)
Scoring Blade Diameter	3⅛" (80mm)
Maximum Depth of Cut at 90°	3¾"
Maximum Depth of Cut at 45°	2⅝"
Blade Tilt	0–45°
Ripping Width (w/Standard Rip Fence)	44½"
Cross Cut Width (Maximum Distance from Left of Blade to Crosscut Fence Stop)	72"
Cross Cut Length (Maximum Distance in Front of Blade)	59"
Maximum Miter Cut Width at 45°	51"

### Construction:

Sliding Table	Aluminum
Machine Frame	Steel
Fence	Extruded Aluminum
Rails	Chromed Steel
Trunnions	Cast Iron

### Motor:

G0461 Motor	7½ HP, 220/440V (Prewired 220V), 20/10A, 3-Phase
G0460 Motor	5 HP, 220V, 22A, Single-Phase
Motor RPM	3450 RPM
Main Blade Arbor	1"
Main Blade Arbor Speed	4900 RPM
Scoring Blade Arbor	20mm
Scoring Arbor Speed	9000 RPM
Ball Bearings	Shielded & Lubricated
Power Transfer	Belt Drive
Switch	Magnetic w/Thermal Overload Protection

### Features:

.....	Blade Guard w/2½" Dust Port
.....	5" Main Dust Port
.....	Adjustable Scoring Knife Kerf
.....	Adjustable Riving Knife
.....	Micro Adjustable, Single Lever Locking Fence

Specifications, while deemed accurate, are not guaranteed.

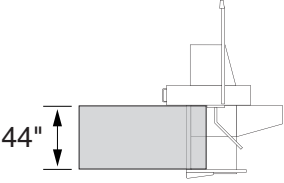
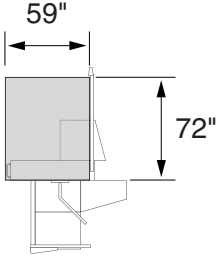
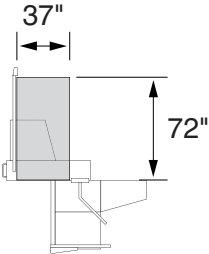
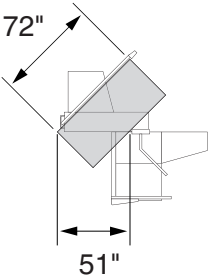
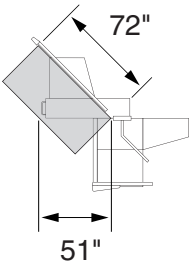
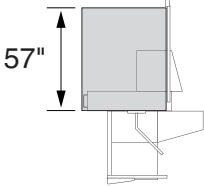
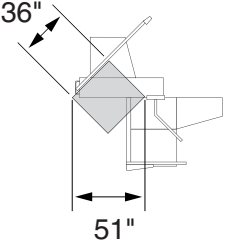
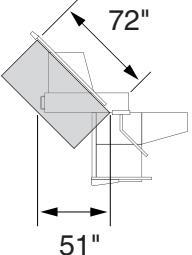




# SLIDING TABLE SAW CAPACITIES

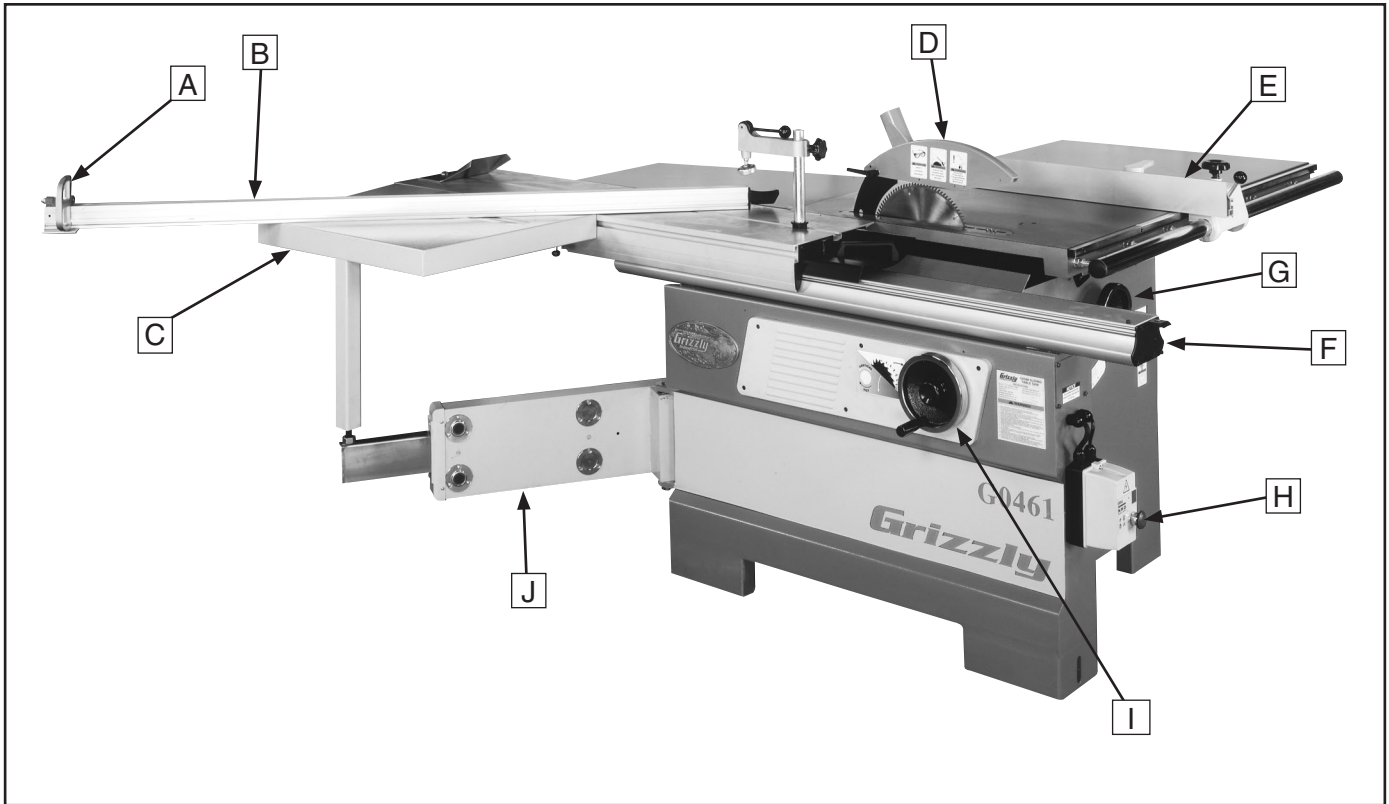
Customer Service #: (570) 546-9663 • To Order Call: (800) 523-4777 • Fax #: (800) 438-5901

## MODELS G0460 & G0461 12" SLIDING TABLE SAWS

 <p>44"</p> <p>Ripping Width</p>	 <p>59"</p> <p>72"</p> <p>Cross Cut</p>
 <p>37"</p> <p>72"</p> <p>Miter Cut 90° (push cut)</p>	 <p>72"</p> <p>51"</p> <p>Miter Cut 45° (push cut)</p>
 <p>72"</p> <p>51"</p> <p>Miter Cut 45°</p>	 <p>57"</p> <p>Cross Cut (fence not extended)</p>
 <p>36"</p> <p>51"</p> <p>Miter Cut 45° (push cut, fence not extended)</p>	 <p>72"</p> <p>51"</p> <p>Miter Cut 45° (fence not extended)</p>



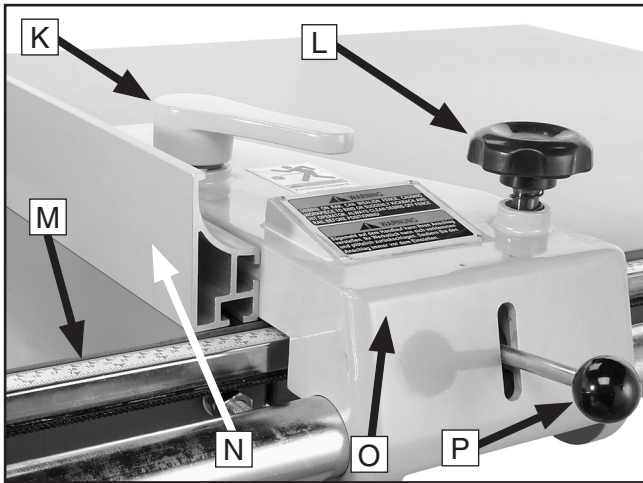
# Identification



**Figure 1.** Main view of machine features and controls.

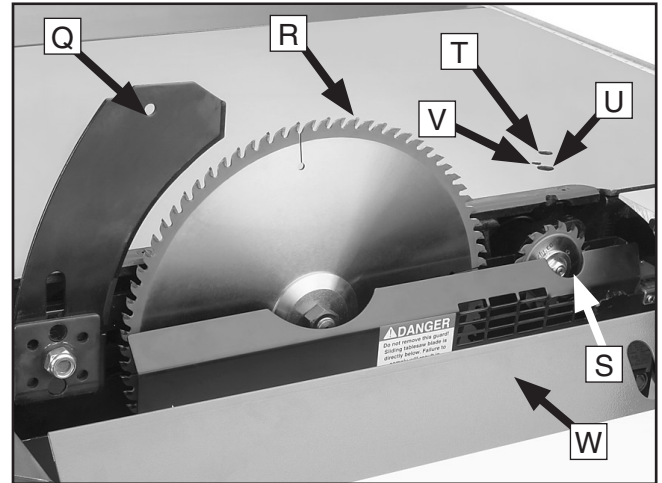
- A. Flip Stops:** Used for quick measurements when crosscutting.
- B. Crosscut Fence:** Used during crosscutting operations. Features a scale and multiple flip-style stop blocks for precise, repeatable crosscutting operations.
- C. Crosscut Table:** Provides a wide, stable platform for supporting full-size panels during crosscutting operations.
- D. Blade Guard:** Fully-adjustable blade guard maintains maximum protection around the saw blade and a 2½" dust port effectively extracts dust from the cutting operation.
- E. Rip Fence:** Fully adjustable with micro-adjustment knob for precision adjustments. Fence face can be positioned for standard cutting operations or for narrow ripping operations.
- F. Sliding Table:** Conveniently glides the workpiece through the blade with effortless precision and ease.
- G. Blade Height Handwheel:** Adjusts the height of the blade.
- H. Magnetic Switch:** Turns the main and scoring blades **ON** or **OFF**. The stop button on the switch has a safety feature that forces the operator to reset the button by rotating it before the machine can be turned **ON** again.
- I. Blade Angle Handwheel:** Adjusts the angle of the saw blades.
- J. Swing Arm:** Supports the crosscut table.





**Figure 2.** Fence controls.

- K. Rip Fence Lock Handle:** Secures the fence face on its forward/backward slide track.
- L. Micro-Adjust Knob:** Precisely adjusts the fence.
- M. Rip Fence Scale:** Allows precise measurement of rip cutting operations.
- N. Fence Face:** The surface that the workpiece slides along.
- O. Fence Body:** Guides the fence along the rail and supports the fence face.
- P. Rip Fence Body Lock Lever:** Secures the fence body in position along the fence rail.



**Figure 3.** Blades.

- Q. Riving Knife:** Maintains kerf opening during cutting operations. This function is crucial to preventing kickback caused by the kerf closing behind the blade.
- R. Main Blade (Not Included):** Performs the cutting operations.
- S. Scoring Blade (Not Included):** Small cutting blade that rotates opposite the main saw blade. The blade scores the workpiece before the actual cutting operation is performed, thus preventing tear-out in laminate materials. The scoring blade is adjustable left and right, up and down, and in kerf thickness.
- T. Scoring Blade Vertical Adjustment Socket:** Internal cap screw adjusts the height of the scoring blade.
- U. Scoring Blade Horizontal Adjustment Socket:** Internal cap screw adjusts the horizontal position of the scoring blade in relation to the main blade.
- V. Scoring Blade Lock Socket:** Locks the scoring blade adjustments.
- W. Lower Blade Guard:** Reduces the risk of accidental operator contact with the blade when the table is at its full extension.





# SECTION 1: SAFETY

## WARNING

### For Your Own Safety, Read Instruction Manual Before Operating this Machine

The purpose of safety symbols is to attract your attention to possible hazardous conditions. This manual uses a series of symbols and signal words which are intended to convey the level of importance of the safety messages. The progression of symbols is described below. Remember that safety messages by themselves do not eliminate danger and are not a substitute for proper accident prevention measures.

 **DANGER** Indicates an imminently hazardous situation which, if not avoided, WILL result in death or serious injury.

 **WARNING** Indicates a potentially hazardous situation which, if not avoided, COULD result in death or serious injury.

 **CAUTION** Indicates a potentially hazardous situation which, if not avoided, MAY result in minor or moderate injury. It may also be used to alert against unsafe practices.

**NOTICE** This symbol is used to alert the user to useful information about proper operation of the machine.

## WARNING

### Safety Instructions for Machinery

- 1. READ THROUGH THE ENTIRE MANUAL BEFORE STARTING MACHINERY.** Machinery presents serious injury hazards to untrained users.
- 2. ALWAYS USE ANSI APPROVED SAFETY GLASSES WHEN OPERATING MACHINERY.** Everyday eyeglasses only have impact resistant lenses, they are NOT safety glasses.
- 3. ALWAYS WEAR AN ANSI APPROVED RESPIRATOR WHEN OPERATING MACHINERY THAT PRODUCES DUST.** Wood dust is a carcinogen and can cause cancer and severe respiratory illnesses.
- 4. ALWAYS USE HEARING PROTECTION WHEN OPERATING MACHINERY.** Machinery noise can cause permanent hearing damage.
- 5. WEAR PROPER APPAREL. DO NOT** wear loose clothing, gloves, neckties, rings, or jewelry which may get caught in moving parts. Wear protective hair covering to contain long hair and wear non-slip footwear.
- 6. NEVER OPERATE MACHINERY WHEN TIRED, OR UNDER THE INFLUENCE OF DRUGS OR ALCOHOL.** Be mentally alert at all times when running machinery.



# WARNING

## Safety Instructions for Machinery

7. **ONLY ALLOW TRAINED AND PROPERLY SUPERVISED PERSONNEL TO OPERATE MACHINERY.** Make sure operation instructions are safe and clearly understood.
8. **KEEP CHILDREN AND VISITORS AWAY.** Keep all children and visitors a safe distance from the work area.
9. **MAKE WORKSHOP CHILD PROOF.** Use padlocks, master switches, and remove start switch keys.
10. **NEVER LEAVE WHEN MACHINE IS RUNNING.** Turn power **OFF** and allow all moving parts to come to a complete stop before leaving machine unattended.
11. **DO NOT USE IN DANGEROUS ENVIRONMENTS.** DO NOT use machinery in damp, wet locations, or where any flammable or noxious fumes may exist.
12. **KEEP WORK AREA CLEAN AND WELL LIT.** Clutter and dark shadows may cause accidents.
13. **USE A GROUNDED EXTENSION CORD RATED FOR THE MACHINE AMPERAGE.** Undersized cords overheat and lose power. Replace extension cords if they become damaged. DO NOT use extension cords for 220V machinery.
14. **ALWAYS DISCONNECT FROM POWER SOURCE BEFORE SERVICING MACHINERY.** Make sure switch is in OFF position before reconnecting.
15. **MAINTAIN MACHINERY WITH CARE.** Keep blades sharp and clean for best and safest performance. Follow instructions for lubricating and changing accessories.
16. **MAKE SURE GUARDS ARE IN PLACE AND WORK CORRECTLY BEFORE USING MACHINERY.**
17. **REMOVE ADJUSTING KEYS AND WRENCHES.** Make a habit of checking for keys and adjusting wrenches before turning machinery **ON**.
18. **CHECK FOR DAMAGED PARTS BEFORE USING MACHINERY.** Check for binding and alignment of parts, broken parts, part mounting, loose bolts, and any other conditions that may affect machine operation. Repair or replace damaged parts.
19. **USE RECOMMENDED ACCESSORIES.** Refer to the instruction manual for recommended accessories. The use of improper accessories may cause risk of injury.
20. **DO NOT FORCE MACHINERY.** Work at the speed for which the machine or accessory was designed.
21. **SECURE WORKPIECE.** Use clamps or a vise to hold the workpiece when practical. A secured workpiece protects your hands and frees both hands to operate the machine.
22. **DO NOT OVERREACH.** Keep proper footing and balance at all times.
23. **MANY MACHINES WILL EJECT THE WORKPIECE TOWARD THE OPERATOR.** Know and avoid conditions that cause the workpiece to "kickback."
24. **ALWAYS LOCK MOBILE BASES (IF USED) BEFORE OPERATING MACHINERY.**
25. **BE AWARE THAT CERTAIN WOODS MAY CAUSE AN ALLERGIC REACTION** in people and animals, especially when exposed to fine dust. Make sure you know what type of wood dust you will be exposed to and always wear an approved respirator.



## WARNING

# Safety Instructions for Sliding Table Saws

- 1. SAFETY ACCESSORIES.** Always use the blade guard and riving knife on all "through-sawing" operations. *Through-sawing operations are those when the blade cuts completely through the workpiece.*
- 2. KICKBACK.** Kickback is defined as high speed expulsion of stock from the table saw toward the operator. *Until you have a clear understanding of kickback and how it occurs, DO NOT operate this table saw!*
- 3. WORKPIECE CONTROL.** Make sure the workpiece is placed in a stable position on the table and is either supported by the rip fence or the crosscut table during cutting operations.
- 4. PUSH STICK.** Always use a push stick when ripping narrow stock.
- 5. OPERATOR POSITION.** Never stand or have any part of your body directly in-line with the cutting path of the saw blade.
- 6. REACHING OVER SAW BLADE.** Never reach behind or over the blade with either hand while the saw is running. *If kickback occurs while reaching over the blade, hands or arms could be pulled into the spinning saw blade.*
- 7. RIP FENCE USAGE.** When using the crosscut fence, the workpiece should never contact the rip fence while the saw blade is cutting.
- 8. STALLED BLADE.** Turn the saw **OFF** before "freeing" a stalled saw blade.
- 9. AWKWARD OPERATIONS.** Avoid awkward operations and hand positions where a sudden slip could cause your hand to move into the spinning saw blade.
- 10. BLADE HEIGHT.** Always adjust the blade to the proper height above the workpiece.
- 11. DAMAGED SAW BLADES.** Never use blades that have been dropped or damaged. A damaged blade could lose teeth while turning, causing injury or death.
- 12. RIVING KNIFE ALIGNMENT.** Only operate the saw if the riving knife is aligned with the main blade to prevent kickback.
- 13. EXPERIENCING DIFFICULTIES.** If at any time you are experiencing difficulties performing the intended operation, stop using the machine! Contact Tech Support at (570) 546-9663.

## WARNING

Like all machines there is danger associated with the Model G0460/G0461. Accidents are frequently caused by lack of familiarity or failure to pay attention. Use this machine with respect and caution to lessen the possibility of operator injury. If normal safety precautions are overlooked or ignored, serious personal injury may occur.

## CAUTION

No list of safety guidelines can be complete. Every shop environment is different. Always consider safety first, as it applies to your individual working conditions. Use this and other machinery with caution and respect. Failure to do so could result in serious personal injury, damage to equipment, or poor work results.



## **WARNING**

Statistics prove that most common accidents among table saw users can be linked to kickback. Kickback is typically defined as the high-speed expulsion of stock from the table saw toward its operator. In addition to the danger of the operator or others in the area being struck by the flying stock, the operator's hands can be pulled into the blade during the kickback.

## Preventing Kickback

---

### Tips to reduce the likelihood of kickback:

- Never attempt freehand cuts. If the workpiece is not fed perfectly parallel with the blade, a kickback will likely occur. Always use the rip fence or crosscut fence to support the workpiece.
- Make sure the riving knife is always aligned with the blade. A misaligned riving knife can cause the workpiece to bind or stop the flow of the cut, resulting in an increased chance of kickback. If you think that your riving knife is not aligned with the blade, check it immediately!
- Ensure that your table slides parallel with the blade; otherwise, the chances of kickback are extreme. Take the time to check and adjust the sliding table.
- Use the riving knife whenever performing a through cut. The riving knife helps maintain the kerf in the workpiece after it is cut, therefore, reducing the chance of kickback.
- Keep the blade guard installed and in good working order. Only remove it when performing non-through cuts and immediately re-install the blade guard when finished with the non-through cut.

- Make multiple, shallow passes when performing a non-through cut. Making a deep non-through cut greatly increases the chance of kickback.
- Feed cuts through to completion. Anytime you stop feeding a workpiece in the middle of a cut, the chance of kickback greatly increases.

## Protecting Yourself from Kickback

---

**Even if you know how to prevent kickback, it may still happen. Here are some tips to reduce the likelihood of injury if kickback DOES occur:**

- Never place your hand behind the blade. Should kickback occur, your hand will be pulled into the blade.
- Stand to the side of the blade during every cut. If a kickback does occur, the thrown workpiece usually travels directly in front of the blade.
- Always wear safety glasses or a face shield. In the event of a kickback, your eyes and face are the most vulnerable part of your body.
- Use a push stick to keep your hands farther away from the moving blade. If kickback occurs, the push stick will most likely take the damage that your hand would have received.



# Glossary of Terms

---

---

The following is a list of common definitions, terms and phrases used throughout this manual. Become familiar with these terms for assembling, adjusting or operating this machine. Your safety is **VERY** important to us at Grizzly!

**Arbor:** A metal shaft extending from the drive mechanism on which the saw blade is mounted.

**Bevel Edge Cut:** Tilting the arbor and saw blade to an angle between 0° and 45° to cut a beveled edge onto a workpiece.

**Blade Guard:** Metal or plastic safety device that mounts over the saw blade to reduce the risk of the accidental operator contact with the saw blade.

**Crosscut:** Cutting operation in which the cross-cut fence is used to cut across the shortest width of the workpiece.

**Dado Blade:** Blade or set of blades that are used to cut grooves and rabbets.

**Dado Cut:** Cutting operation that uses a dado blade to cut a flat bottomed groove into the face of the workpiece.

**Featherboard:** Safety device used to keep the workpiece against the rip fence and against the table surface.

**Kerf:** The cut or gap in the workpiece after the saw blade cuts through it.

**Kickback:** When the workpiece is propelled back towards the operator at a high rate of speed.

**Parallel:** Being an equal distance apart at every point along two given lines or planes (i.e. the rip fence face is parallel to the face of the saw blade).

**Non-Through Cut:** A sawing operation that requires the removal of the blade guard and riving knife. Dado and rabbet cuts are considered Non-Through Cuts because the blade does not protrude above the top face of the wood stock. Deep Non-Through Cuts must be made with multiple, light passes to reduce the risk of kickback. Always remember to re-install the blade guard and riving knife after performing a non-through cut.

**Perpendicular:** Lines or planes that intersect and form right angles (i.e. the blade is perpendicular to the table surface).

**Push Stick:** Safety device used to push the workpiece through a cutting operation, while keeping the operator's hands away from the blade. Used most often when rip cutting thin workpieces.

**Rabbet:** Cutting operation that creates an L-shaped channel along the edge of the workpiece.

**Riving Knife (Splitter):** Metal plate located behind the blade that maintains the kerf opening in the wood during a cut.

**Straightedge:** A tool used to check the flatness, parallelism, or consistency of a surface(s).

**Through Cut:** A sawing operation in which the workpiece is completely sawn through.

**Rip Cut:** Cutting operation in which the rip fence is used to cut across the widest width of the workpiece.



# SECTION 2: CIRCUIT REQUIREMENTS

## **⚠️ WARNING**

Serious personal injury could occur if you connect the machine to the power source before you have completed the setup process. **DO NOT** connect the machine to the power source until instructed to do so.

### Full Load Amperage Draw

G0460 5 HP 220V 1-Phase.....	22 Amps
G0461 7.5 HP 220V 3-Phase.....	20 Amps
G0461 7.5 HP 440V 3-Phase.....	10 Amps

### Circuit Requirements

We recommend connecting your machine to a dedicated and grounded circuit that is rated for the amperage given below. Never replace a circuit breaker on an existing circuit with one of higher amperage without consulting a qualified electrician to ensure compliance with wiring codes. **If you are unsure about the wiring codes in your area or you plan to connect your machine to a shared circuit, consult a qualified electrician.**

G0460 220V 1-Phase.....	30 Amp
G0461 220V 3-Phase.....	30 Amp
G0461 440V 3-Phase.....	15 Amp

### Minimum Cord Requirements

For 220V connection, we recommend using a stranded-copper flexible cord that meets the minimum criteria listed below, does not exceed 50 ft., and has an insulation type that starts with "S." The exact insulation type should account for any exposure to moisture, heat, and oils in the working environment.

G0460 220V 1-Phase.....	10/3 AWG, 300VAC
G0461 220V 3-Phase.....	10/4 AWG, 300VAC
G0461 440V 3-Phase.....	Electrician to Hardwire

### 220V Plug/Connection Type

G0460 220V 1-Phase.....	L6-30
G0461 220V 3-Phase.....	L15-30

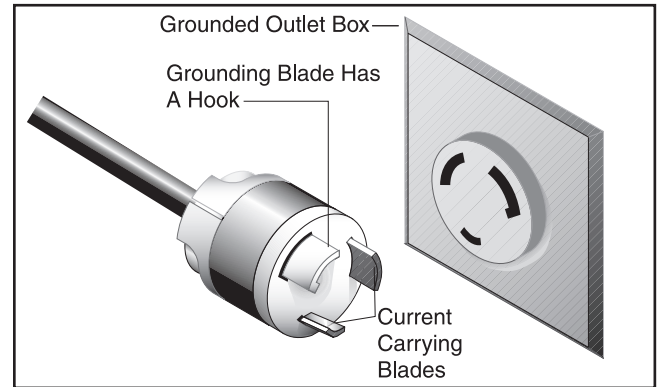


Figure 4. NEMA L6-30 plug and receptacle.

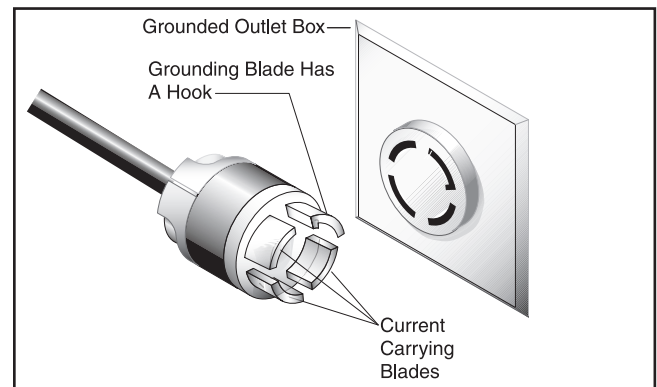


Figure 5. NEMA L15-30 plug and receptacle.

### G0461 440V Connection to Power

Have a qualified electrician hardwire this machine to a dedicated locking shut-off switch that is connected to the main power source.

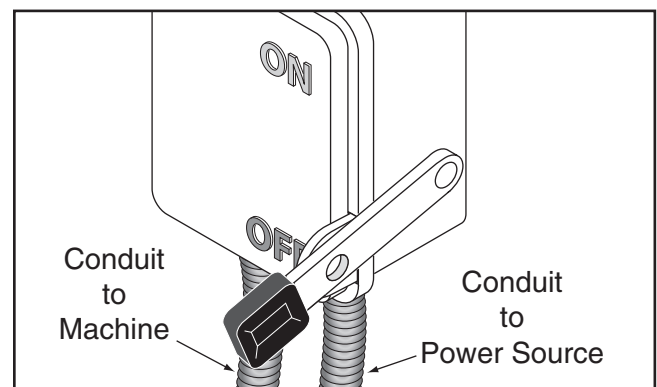
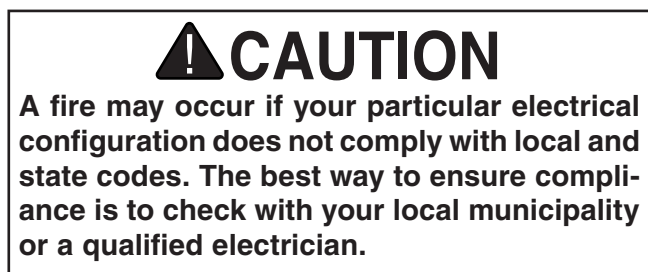
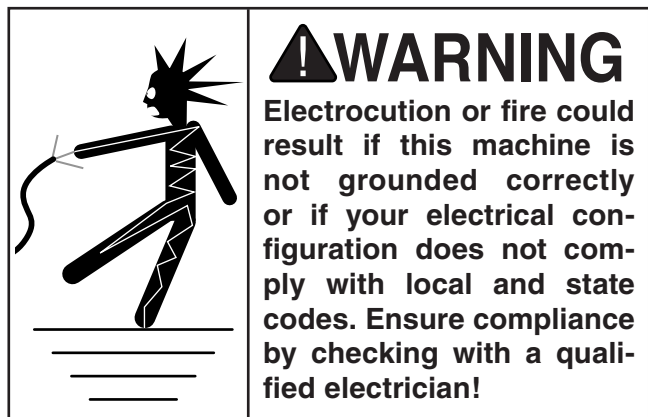


Figure 6. Hardwired locking disconnect switch.



## Grounding

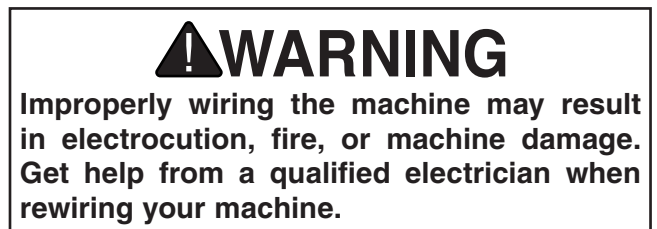
In the event of an electrical short, grounding reduces the risk of electric shock. Improper connections of the electrical-grounding conductor increase the risk of electric shock. Ensure that this machine is properly grounded before operating it.



## Rewiring to 440V

The Model G0461 can be rewired for 440V operation. This rewiring job consists of disconnecting the saw from the power source, installing the magnetic switch assembly from the 440V conversion kit, and rewiring the motor.

The necessary components for this procedure can be purchased by calling our Customer Service number at (800) 523-4777 and ordering the 440V conversion kit (item #P0461199).



To rewire the Model G0461 for 440V operation:

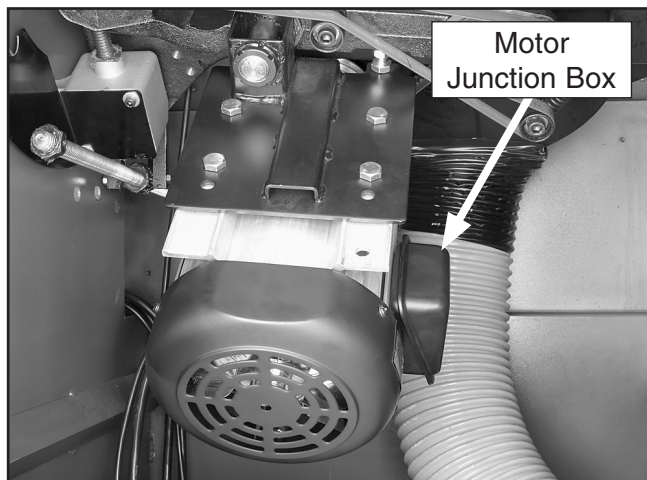
1. DISCONNECT MACHINE FROM POWER!
2. Remove the motor cabinet cover shown in **Figure 7**.



**Figure 7.** Motor cabinet cover.



3. Remove the motor junction box cover (see **Figure 8**).

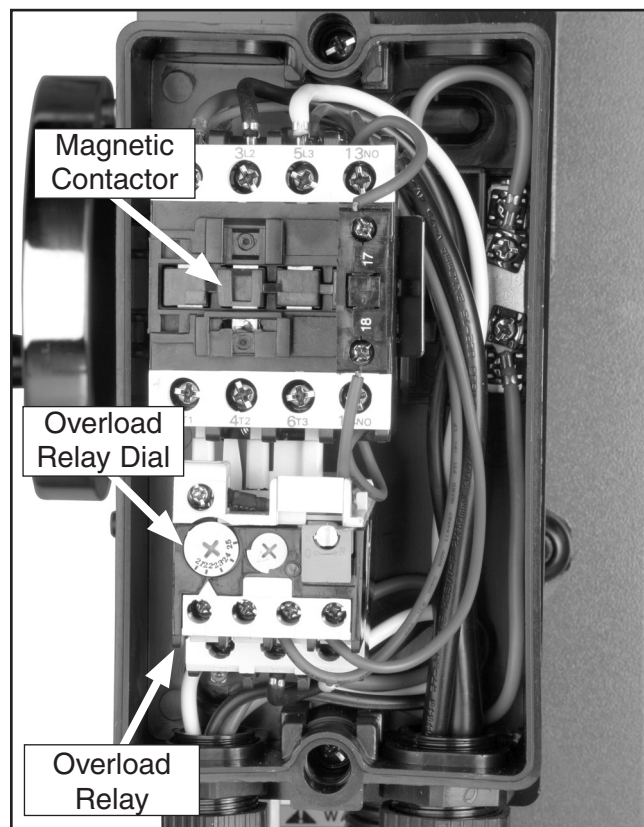


**Figure 8.** Motor location.

4. Rewire the motor per the diagram on the inside of the motor junction box, using the additional wiring nuts included with the 440V conversion kit.

**Note:** A wiring diagram is provided in the back of this manual for your reference; it is current at the time of printing, but the machine may change. The diagram on the inside of the motor junction box will always be current with the motor.

5. Remove the magnetic switch cover.
6. Replace the original magnetic switch assembly with the assembly included in the 440V conversion kit. Set the dial on the new overload relay to 11A (**Figure 9**).



**Figure 9.** Magnetic switch.

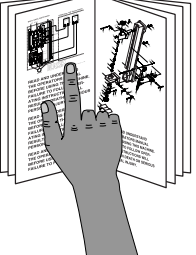
7. Reinstall the switch cover.





# SECTION 3: SETUP


## Setup Safety



**⚠️ WARNING**  
 This machine presents serious injury hazards to untrained users. Read through this entire manual to become familiar with the controls and operations before starting the machine!



**⚠️ WARNING**  
 Wear safety glasses during the entire setup process!



**⚠️ WARNING**  
 The Model G0460/G0461 is a very heavy machine. Serious personal injury may occur if safe moving methods are not followed. To be safe, get assistance and use power equipment when moving the crate and removing the machine from the crate.



**⚠️ CAUTION**  
 Unsupervised children and visitors inside your shop could cause serious personal injury to themselves. Lock all entrances to the shop when you are away and **DO NOT** allow unsupervised children or visitors in your shop at any time!

## Unpacking

The Model G0460/G0461 was carefully packed when it left our warehouse. If you discover the machine is damaged after you have signed for delivery, *please immediately call Customer Service at (570) 546-9663 for advice.*

Save the containers and all packing materials for possible inspection by the carrier or its agent. *Otherwise, filing a freight claim can be difficult.*

When you are completely satisfied with the condition of your shipment, you should inventory the contents.

## Items Needed for Setup

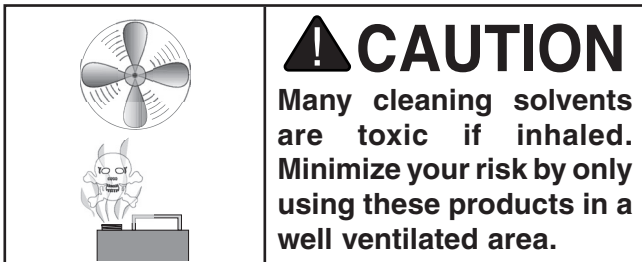
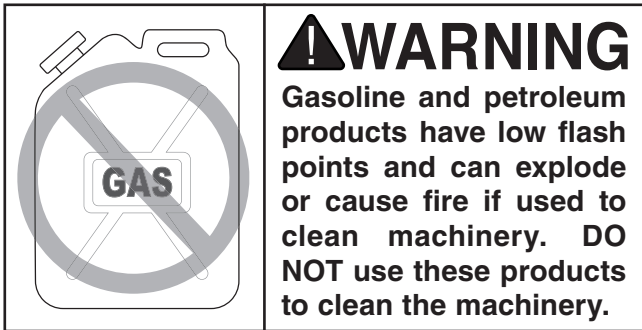
The following items are needed to complete the setup, but are not included with your machine:

Description	Qty
• Safety Glasses (for each person) .....	1
• Forklift or Other Power Lifting Equipment..	1
• Lifting Straps (1500 lb capacity).....	2
• An Assistant to Help with Heavy Items .....	1
• Main Blade 12" (305mm) .....	1
• Scoring Blade 3" (80mm) .....	1
• High Quality Straightedge .....	1
• Phillips Head Screwdriver .....	1
• Machinist's Square .....	1
• Framing Square.....	1
• Dust Collection System .....	1
• 5" Dust Hose and Hose Clamps .....	1
• 2½" Dust Hose and Hose Clamps .....	1



# Clean Up

The unpainted surfaces are coated with a waxy oil to prevent corrosion during shipment. Remove this protective coating with a solvent cleaner or citrus-based degreaser such as Grizzly's G7895 Citrus Degreaser. To clean thoroughly, some parts must be removed. **For optimum performance from your machine, clean all moving parts or sliding contact surfaces.** Avoid chlorine-based solvents, such as acetone or brake parts cleaner that may damage painted surfaces. Always follow the manufacturer's instructions when using any type of cleaning product.



## G7895—Grizzly Citrus Degreaser

This natural, citrus-based degreaser is a great solution for removing export grease, and it's much safer to work around than nasty solvents.



Figure 10. Grizzly citrus degreaser.

# Inventory

After all the parts have been removed from the two boxes, you should have the following items included with the base unit of the saw:

Inventory .....	Qty
A. Large Extension Wing .....	1
B. Small Extension Wing w/Set Screws .....	1
C. Support Leg w/Hex Bolt & Nut .....	1

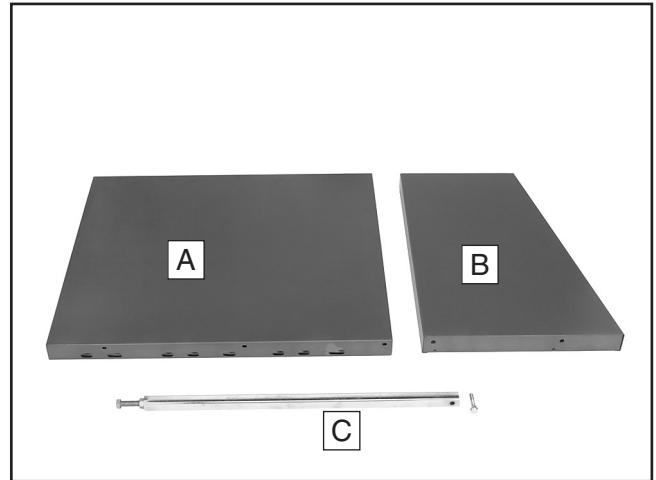


Figure 11. Extension table components.

D. Round Rail w/M12 Studs, Washers, and Nuts.....	1
E. Square Tube w/Scale.....	1
F. Aluminium Rip Fence .....	1
G. Rip Fence Body.....	1

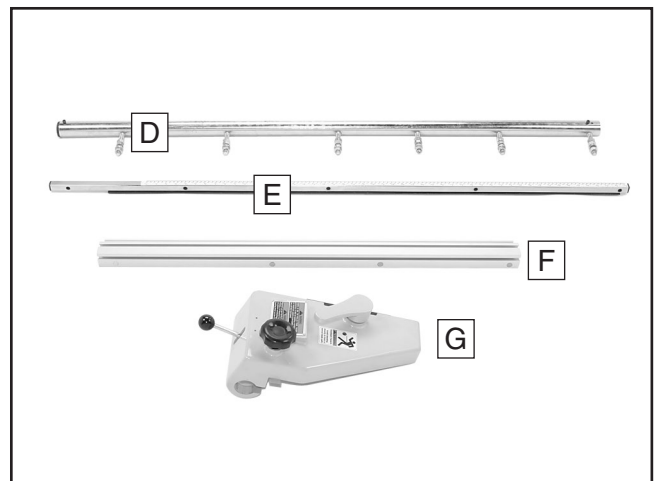
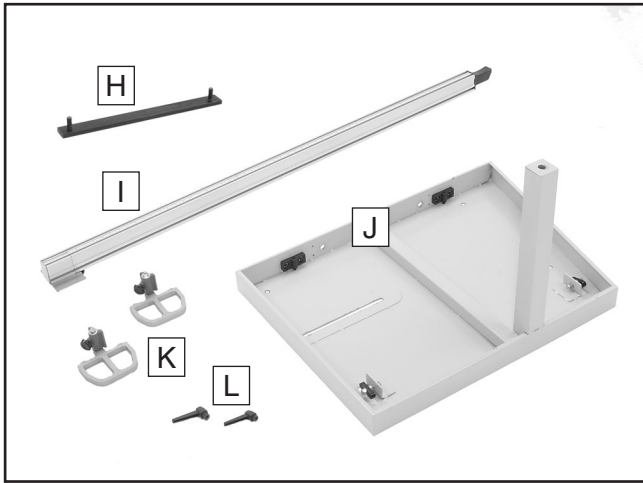


Figure 12. Rip fence components.

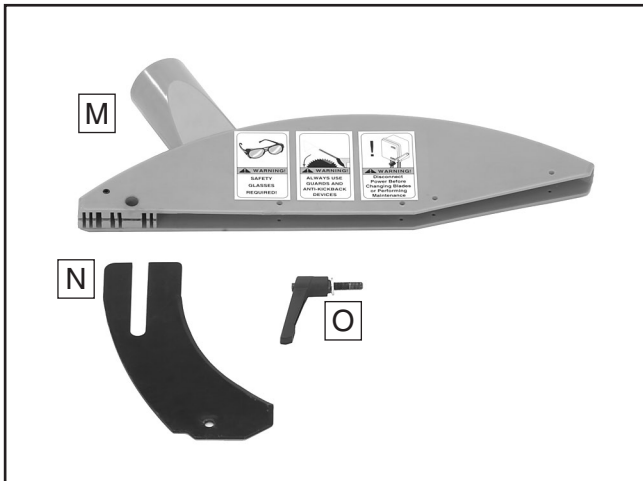


- H. Lock Plate..... 1
- I. Crosscut Aluminium Fence ..... 1
- J. Crosscut Table ..... 1
- K. Flip Stops w/Knobs, T-Nuts & Washers..... 2
- L. Adjustable Handles ..... 2



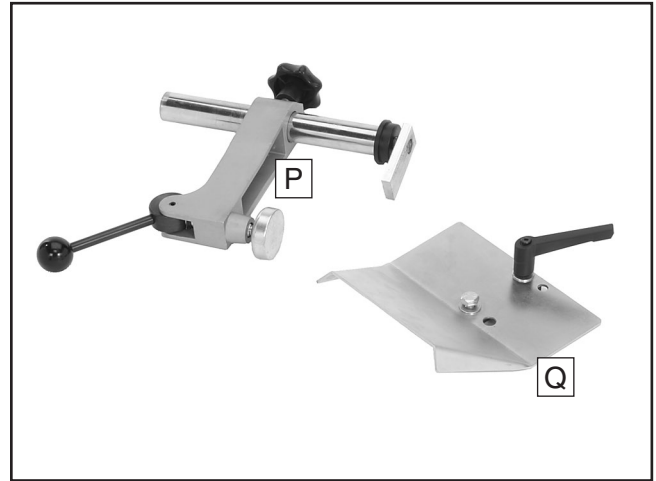
**Figure 13.** Crosscut table components.

- M. Blade Guard Dust Hood ..... 1
- N. Riving Knife ..... 1
- O. Adjustable Handle M8-1.25 x 28 ..... 1



**Figure 14.** Blade guard components.

- P. Hold-down ..... 1
- Q. Edge Shoe..... 1



**Figure 15.** Included accessories.

**Hardware and Tools**

- Hex Bolt M10-1.5 x 45 (Leg/Large Wing) .. 1
- Lock Washer 10mm (Leg/Large Wing) ..... 1
- Flat Washer 10mm (Leg/Large Wing) ..... 1
- Cap Screws M8-1.25 x 25 (Large Wing/Table)..... 2
- Lock Washers 8mm (Large Wing/Table) ... 2
- Flat Washers 8mm (Large Wing/Table) ..... 2
- Cap Screws M8-1.25 x 25 (Small Wing/Table)..... 2
- Lock Washers 8mm (Small Wing/Table).... 2
- Flat Washers 8mm (Small Wing/Table) ..... 2
- Cap Screws M6-1 x 20 (Scale/Table) ..... 5
- Flat Washers 6mm (Scale/Table)..... 3
- Hex Nuts M6-1 (Scale/Table)..... 3
- T-Hex Wrenches 6, 5, 4mm ..... 1 Ea
- Hex Wrenches 6, 5, 4, 3, 2mm ..... 1 Ea
- Open End Wrenches 10/12, 14/17, 22/24mm ..... 1 Ea
- Combo Wrenches 13, 19mm ..... 1 Ea
- Push Stick ..... 1
- Long Knobs M10-1.5 (Crosscut Fence) ..... 2

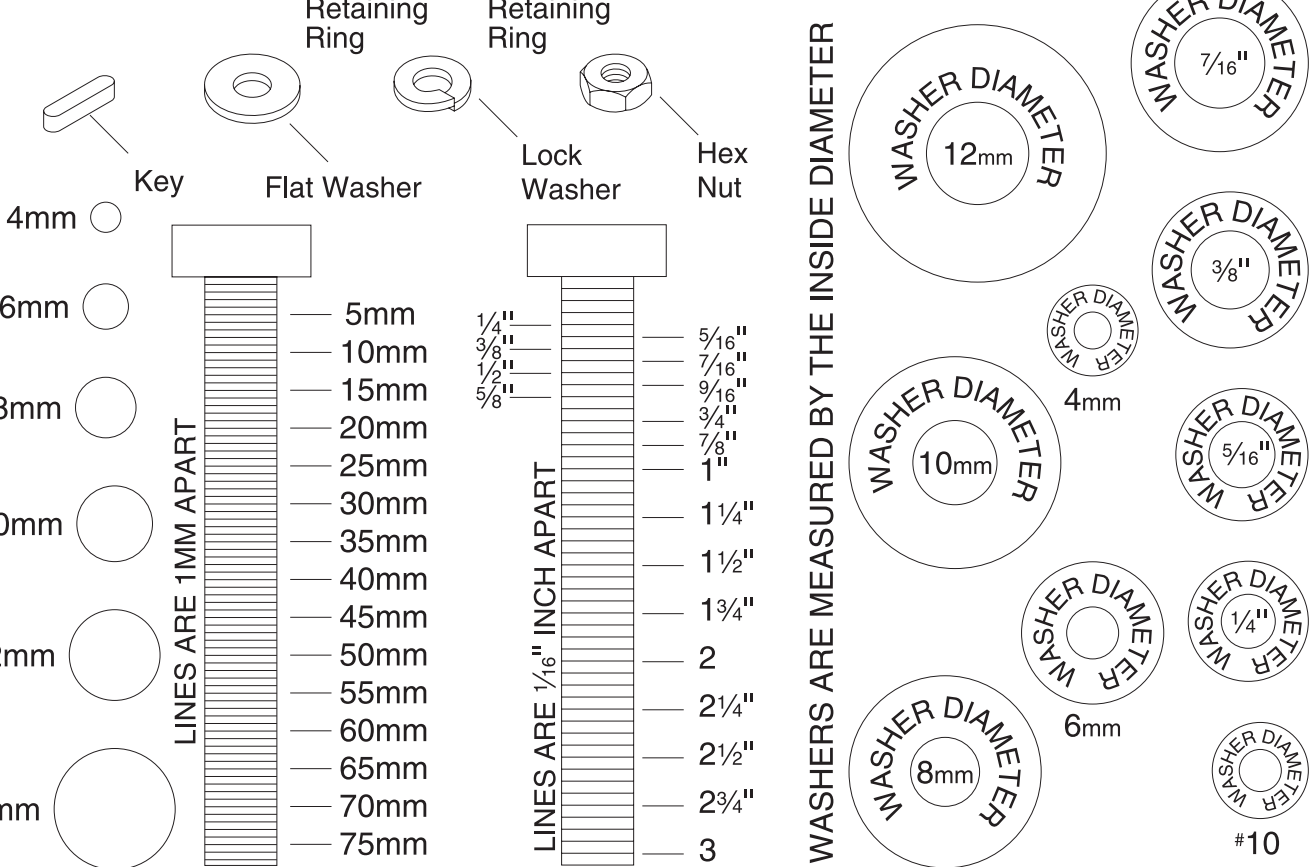
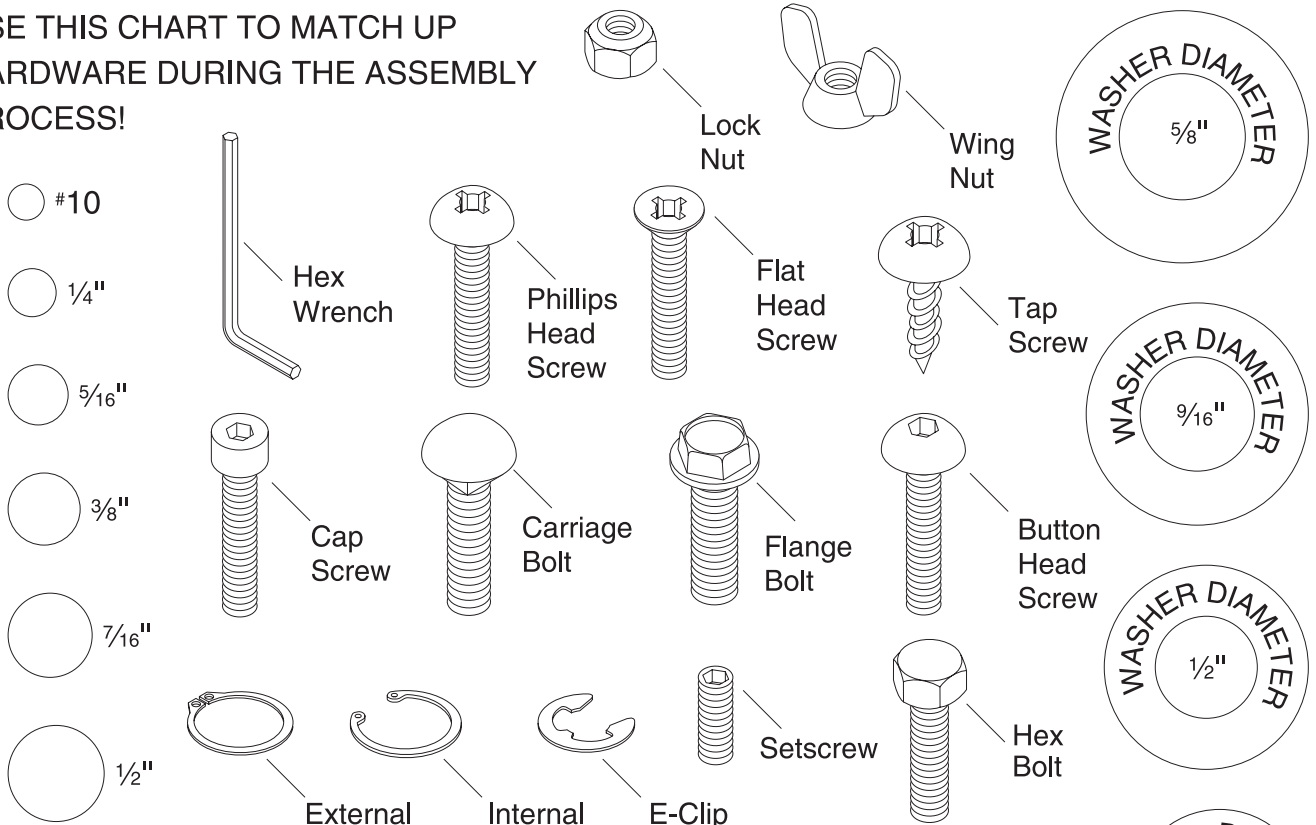
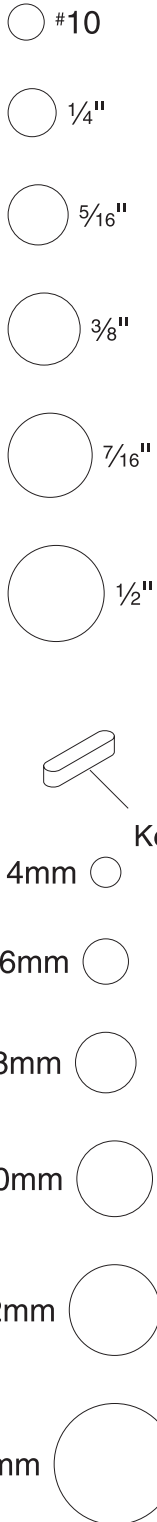
In the event that any nonproprietary parts are missing (e.g. a nut or a washer), we would be glad to replace them, or for the sake of expediency, replacements can be obtained at your local hardware store.



# Hardware Recognition Chart

USE THIS CHART TO MATCH UP  
HARDWARE DURING THE ASSEMBLY  
PROCESS!

MEASURE BOLT DIAMETER BY PLACING INSIDE CIRCLE



WASHERS ARE MEASURED BY THE INSIDE DIAMETER



# Site Considerations

## Floor Load

Most commercial floors are suitable for this machine. Residential floors may require additional reinforcement to support the machine and operator. Refer to the **Machine Data Sheet** on **Page 3** for details about the weight and foot print size.

## Placement

Consider existing and anticipated needs, size of material to be processed through your machine, and space for auxiliary stands, work tables or other machinery when establishing a location for your saw. See **Figure 16** for the minimum operating clearances of the Model G0460/G0461.

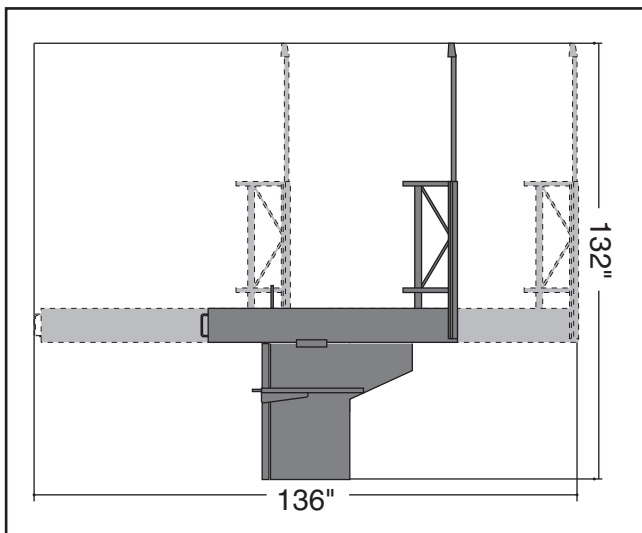


Figure 16. Operating clearances.

# Moving & Placing Base Unit

## ⚠ WARNING

Use lifting straps with a 1500 lbs. minimum lifting capacity. If a lifting strap breaks, serious personal injury may occur.

To remove the saw base unit from the crate pallet:

1. Remove the top of the crate and position the forklift forks together and directly above the saw.
2. Place two lifting straps (with hooks on the ends) over the forks and slide the hooks into the points shown in **Figure 17**.



Figure 17. Lifting the saw base unit.

## ⚠ WARNING

DO NOT lift the table saw any higher than necessary to clear the floor. Serious personal injury and damage to the machine may occur if safe moving methods are not followed.

3. Lift the saw base unit and move it to your predetermined location.



# Mounting to Shop Floor

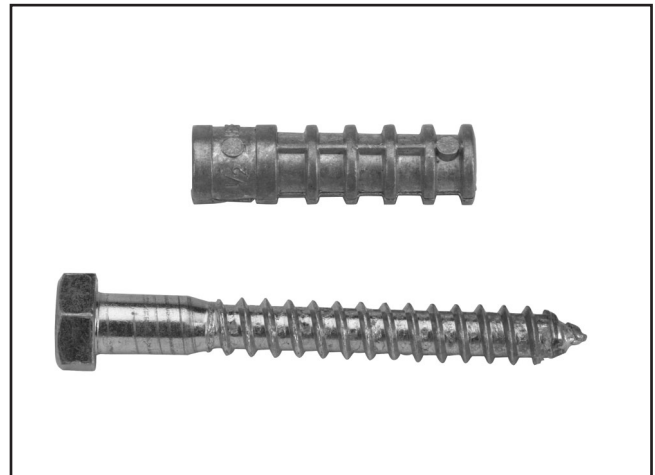
Although not required, we recommend that you mount your new machine to the floor. Because this is an optional step and floor materials may vary, floor mounting hardware is not included. However you decide to mount your machine, we strongly suggest leveling the machine with a precision level before bolting it down.

## Bolting to Concrete Floors

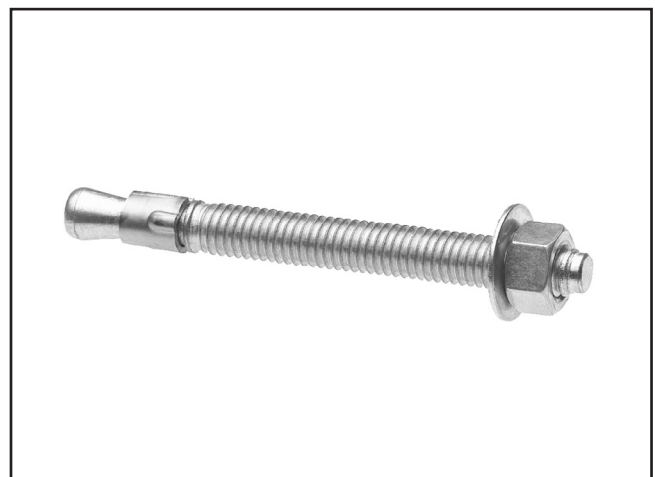
Lag shield anchors with lag bolts (**Figure 18**) and anchor studs (**Figure 19**) are two popular methods for anchoring an object to a concrete floor. We suggest you research the many options and methods for mounting your machine and choose the best that fits your specific application.

### **NOTICE**

Anchor studs are stronger and more permanent alternatives to lag shield anchors; however, they will stick out of the floor, which may cause a tripping hazard if you decide to move your machine.



**Figure 18.** Typical lag shield anchor and lag bolt.



**Figure 19.** Typical anchor stud.

### **NOTICE**

We strongly recommend securing your machine to the floor if it is hardwired to the power source. Consult with your electrician to ensure compliance with local codes.



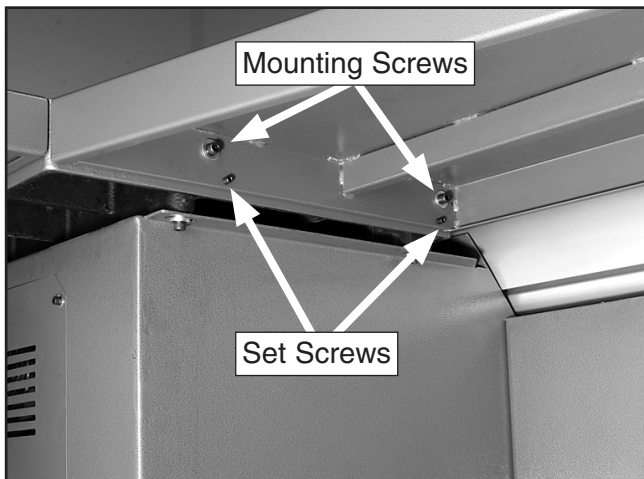
# Extension Tables

<b>Components and Hardware Needed:</b>	<b>Qty</b>
Large Extension Wing .....	1
Small Extension Wing w/Set Screws .....	1
Support Leg w/Hex Bolt & Nut .....	1
Cap Screws M8-1.25 x 25 (Small Wing/Table).....	2
Lock Washers 8mm (Small Wing/Table).....	2
Flat Washers 8mm (Small Wing/Table) .....	2
Cap Screws M8-1.25 x 25 (Large Wing/Table).....	2
Lock Washers 8mm (Large Wing/Table).....	2
Flat Washers 8mm (Large Wing/Table) .....	2
Hex Bolt M10-1.5 x 45 (Leg/Large Wing).....	1
Lock Washer 10mm (Leg/Large Wing) .....	1
Flat Washer 10mm (Leg/Large Wing).....	1

## To install the extension tables:

1. Make sure the set screws in the small extension wing do not stick out from the mating surface.
2. Attach the small extension wing with two M8-1.25 x 25 cap screws, lock washers, and flat washers as shown in **Figure 20**.

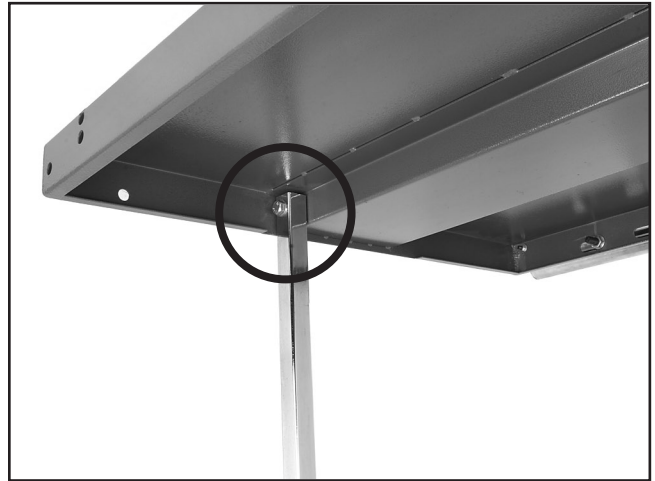
**Note:** Get assistance positioning the tables and holding them in place while installing.



**Figure 20.** Small extension wing attached.

3. Attach the large extension wing to the back of the machine with the two M8-1.25 x 25 cap screws, lock washers, and flat washers.

4. Attach the support leg (**Figure 21**) to the large extension wing with the M10-1.5 x 45 hex bolt, lock washer, and flat washer.



**Figure 21.** Support leg installed.

5. Check the table surfaces with a straightedge, as shown in **Figure 22**, to ensure that they are flush and even with each other.



**Figure 22.** Checking with a straightedge.

6. Adjust the set screws under the small extension wing to align it with the main table surface. (You may need to slightly loosen the wing mounting cap screws to adjust the wing position.)
7. Use the hex bolt in the bottom of the support leg to level the surface of the large extension wing.
8. Tighten all of the wing mounting cap screws.

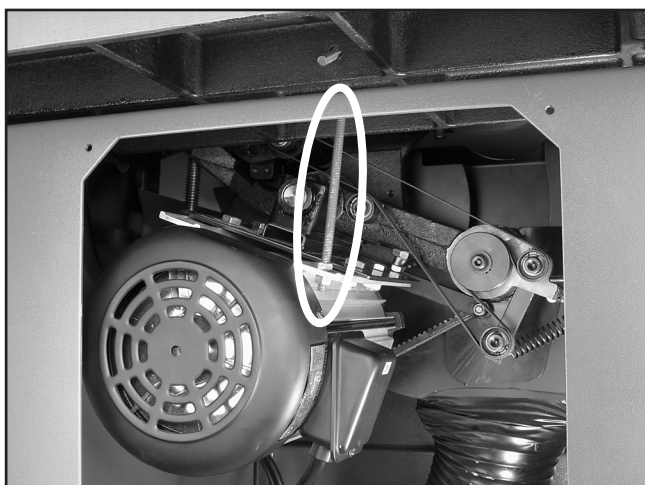


# Main Blade

Components and Hardware Needed:	Qty
Blade 12" (Not Included) .....	1
Riving Knife .....	1

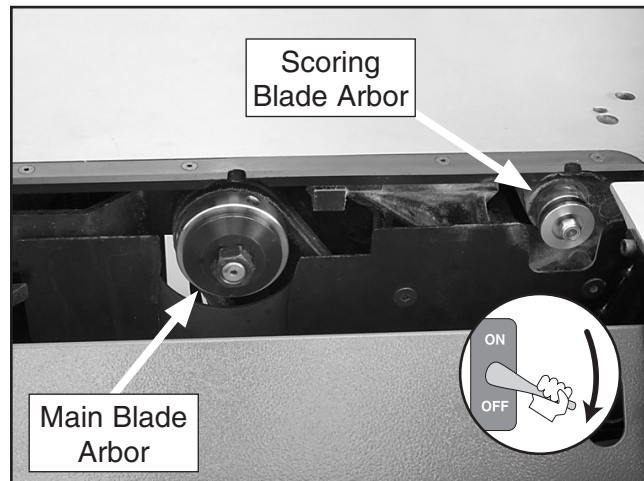
## To install the blade:

1. DISCONNECT SAW FROM POWER!
2. Open the cabinet and remove the red motor support bolt, shown in **Figure 23**, by removing the nut and tilting the blade assembly to clear the bolt.



**Figure 23.** Motor support shipping bolt.

3. Move the blade tilt to 0° (blade 90° to table) and raise the main blade arbor.
4. Slide the table all the way forward to access the blade arbor, loosen the flange bolt securing the lower blade guard, slide the bolt up, and pull open the lower blade guard (see **Figure 24**).



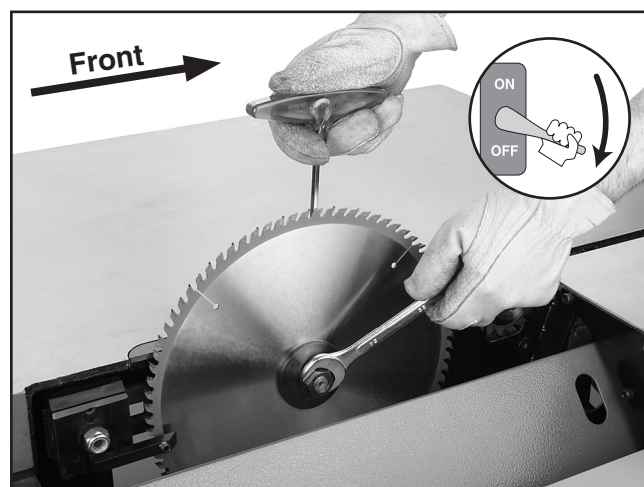
**Figure 24.** Main blade arbor components.

5. Place a hex wrench in the hole in the arbor to prevent the arbor from rotating, then use the arbor wrench to remove the arbor nut and arbor flange.

**Note:** The arbor nut has left-hand threads and loosens by turning clockwise.

6. Slide the blade onto the arbor with the teeth facing the front of the saw (see **Figure 25**).

**Note:** Wear heavy leather gloves to protect your hands when installing or removing blades.



**Figure 25.** Installing the main blade.

7. Re-install the arbor flange and the arbor nut then tighten them against the blade as shown in **Figure 25**.
8. Close the lower blade guard and secure it closed with the flange bolt.





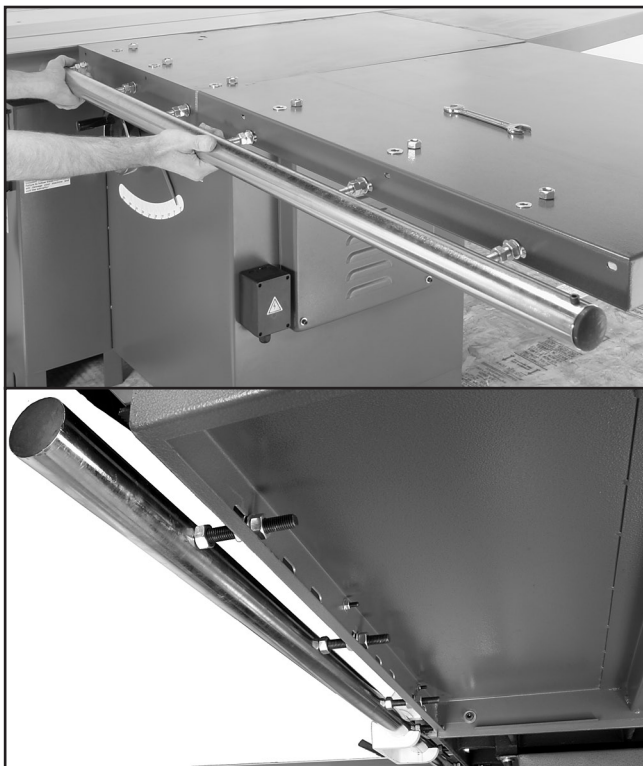
# Rip Fence and Scale

Components and Hardware Needed:	Qty
Rip Fence .....	1
Round Rail.....	1
Rip Fence Body.....	1
Square Tube w/Scale.....	1
Flat Washers 6mm (Scale/Table).....	5
Hex Nuts M6-1 (Scale/Table).....	5
Cap Screws M6-1 x 20 (Scale/Table) .....	5

The accuracy of the rip fence being parallel to the blade is dependent on the position of the round rail. The round rail is equipped with hex nuts on mounting studs to precisely adjust the position of the round rail when bringing the rip fence parallel to the blade.

## To install the rip fence:

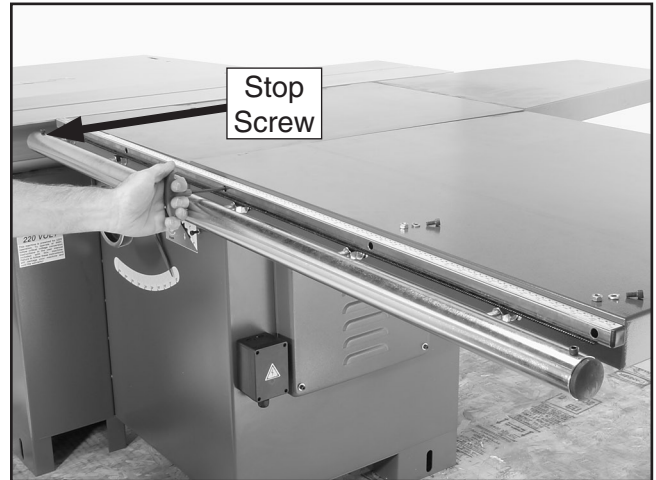
1. DISCONNECT SAW FROM POWER!
2. Remove a hex nut and a flat washer from each of the studs in the round rail.
3. Insert the studs into the table as shown in **Figure 26**, and loosely secure with the hex nuts and flat washers removed in **Step 1**.



**Figure 26.** Installing the round rail.

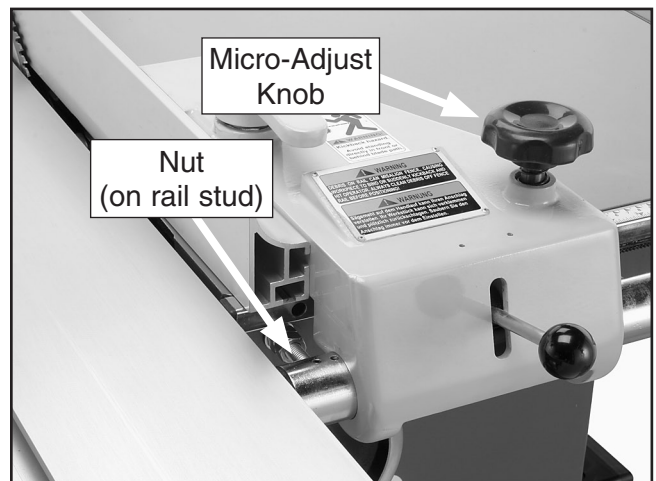
4. Align the square tube w/scale parallel with the top of the table and secure it with the five cap screws, flat washers, and hex nuts (see **Figure 27**).

**Note:** Two of the cap screws attach directly into the table without washers or hex nuts.



**Figure 27.** Attaching the scale.

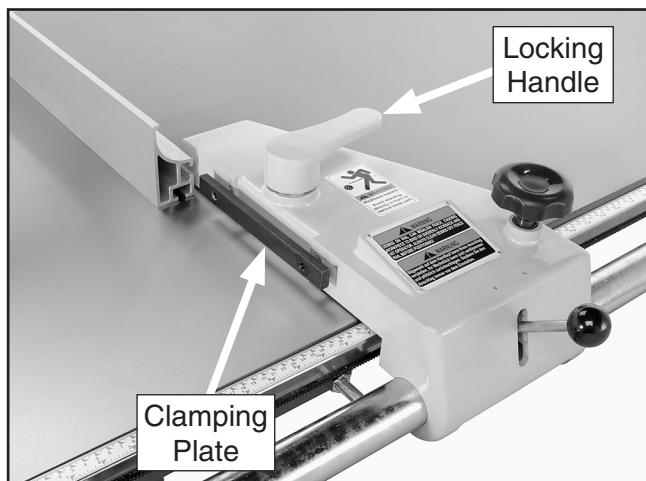
5. Slide the rip fence body onto the rail and move it all the way to the left, until it stops against the stop screw at the end of the rail.
6. Adjust the nut shown in **Figure 28** until the pinion gear teeth under the rip fence body mesh with the teeth on the square tube when the micro-adjust knob is pushed down. Tighten the hex nuts on that stud to secure the rail on that end.



**Figure 28.** Aligning the round rail.

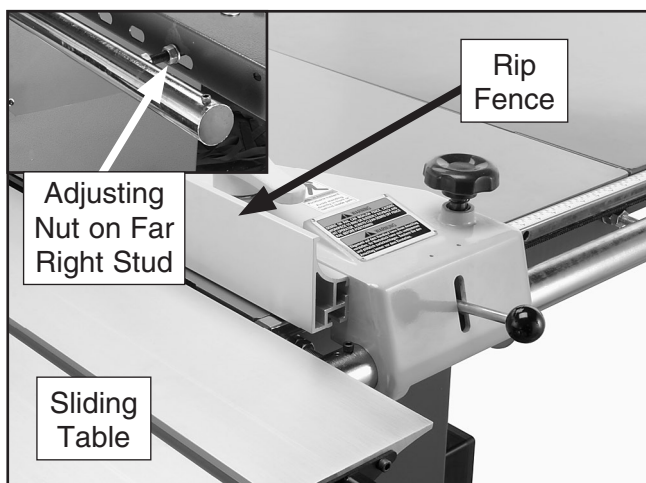


- Slide the rip fence all the way onto the clamping plate (**Figure 29**) and secure it by rotating the locking handle on top of the rip fence body.



**Figure 29.** Installing the rip fence.

- Raise the blade all the way up and adjust it to 90°.
- Remove the stop screw on the left hand side of the rail, and slide the fence over until it just touches the blade.
- Adjust the round rail mounting position on the table by rotating the adjusting nut on the far right stud (of the round rail) until the rip fence is parallel with the blade as shown in **Figure 30**. (See **Figure 26** for a better view of all the round rail studs and adjusting nuts.)



**Figure 30.** Aligning the fence with the blade.

- Tighten the hex nuts on that stud to secure the rail to the table on that end (one of the nuts acts as a jam nut and tightens against the other one to keep the setting).

**Note:** Leave the center studs loose until the adjustments are complete.

- Slide the fence to the middle of the round rail, and replace the stop screw.
- Slide the fence back-and-forth across the round rail. Make sure the gap between the rip fence body and the table is equal along the entire distance—and that the micro adjustment knob engages at both ends of the rail when it is pushed down and rotated.

—If the gap between the fence and table is even—and the micro-adjustment knob engages—continue to the next step.

—If the gap between the fence and the table is NOT even—or the micro-adjustment knob DOES NOT engage—then loosen the nuts on both ends of the rail and repeat **Steps 9–13**.

- Tighten all of the nuts securing the rail against the table (see **Figure 31**) and tighten the outside nuts against the adjusting nuts.



**Figure 31.** Rip fence rail adjustment nuts.

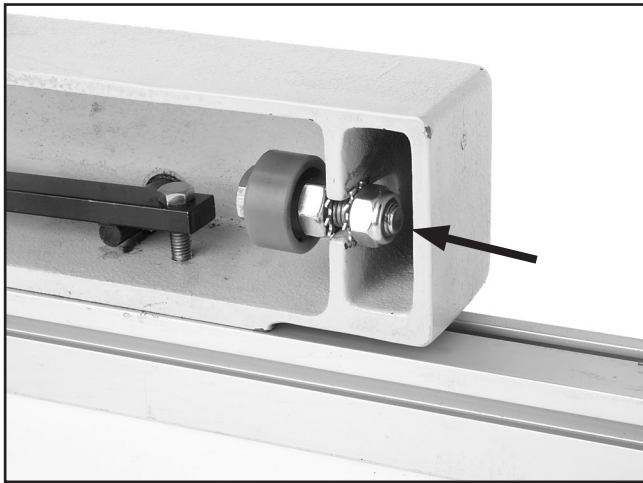


15. Check if the bottom of the rip fence rests on the surface of the table.

**Note:** *The rip fence will scratch the table if the ride height is not adjusted correctly.*

—If the rip fence DOES NOT rest on the table, then the fence is correctly adjusted.

—If the rip fence rests on the table, loosen the hex nut shown in **Figure 32** and rotate the hex bolt to raise the roller. Tighten the hex nut to lock the height.

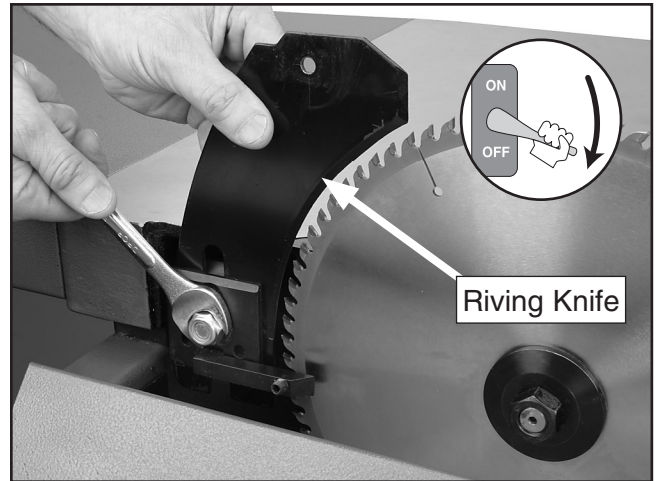


**Figure 32.** Rip fence height adjustment.

## Riving Knife

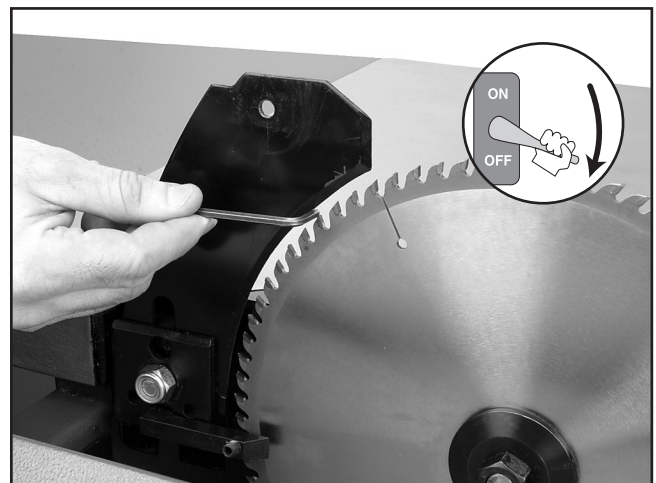
**To install the riving knife:**

1. DISCONNECT SAW FROM POWER!
2. Loosen the riving knife center bolt, slide the riving knife between the plates as shown in **Figure 33**, and slightly tighten.



**Figure 33.** Installing the riving knife.

3. Position the riving knife about 3mm or 1/8" away from the nearest carbide tooth on the main blade. **Note:** *For a quick gauge, use the 3mm hex wrench to find the correct spacing between the blade and the riving knife, as shown in **Figure 34**.*



**Figure 34.** Adjusting the riving knife.

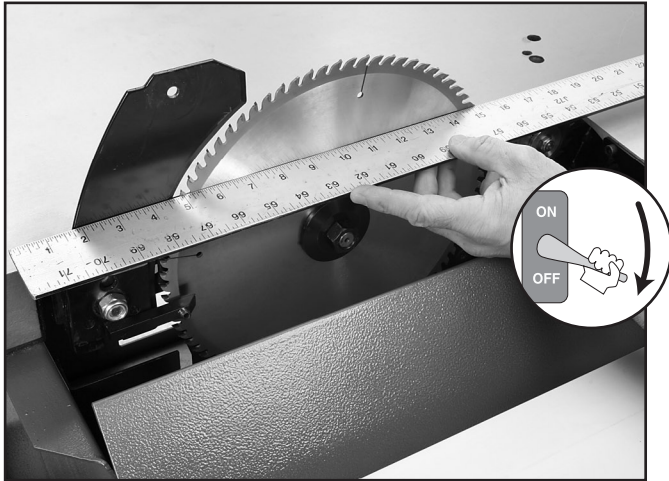
4. Tighten the center bolt to secure the riving knife in position.



5. Check the blade alignment on both sides of the riving knife with a straightedge, as shown in **Figure 35**.

—If the straightedge touches the riving knife evenly on both sides, go to **Step 5**.

—If the straightedge only touches the riving knife on one side, go to **Step 6**.

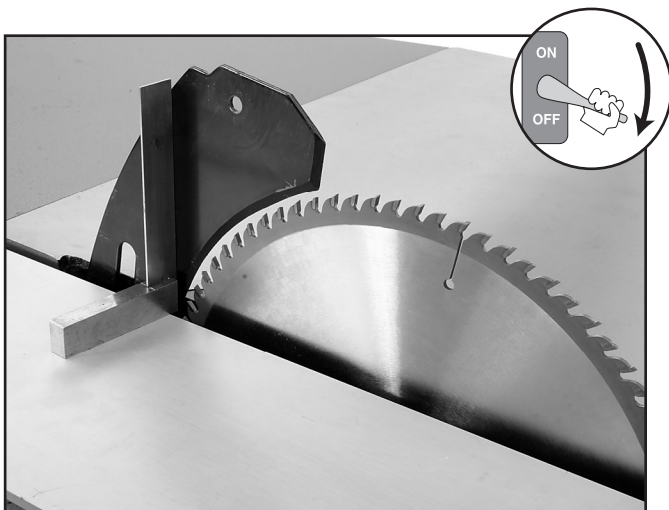


**Figure 35.** Checking riving knife alignment.

6. Place a machinist's square flat on the table and slide it against the riving knife as shown in **Figure 36**.

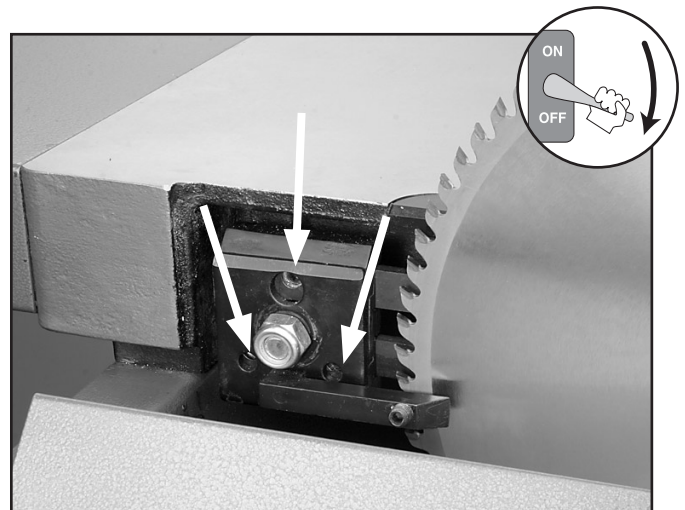
—If the square lies flat against the riving knife, the riving knife is correctly adjusted.

—If there is a gap between the square and the riving knife, go to **Step 6**.



**Figure 36.** Checking vertical alignment.

7. Slide the table all the way forward to access the blade arbor.
8. Loosen the flange bolt securing the lower blade guard, slide the flange bolt up, and pull open the lower blade guard.
9. Loosen the riving knife center bolt and remove the riving knife.
10. Use the set screws shown in **Figure 37** to adjust the riving knife bracket, so the riving knife aligns with the main blade when re-installed.



**Figure 37.** Set screws for adjusting riving knife.



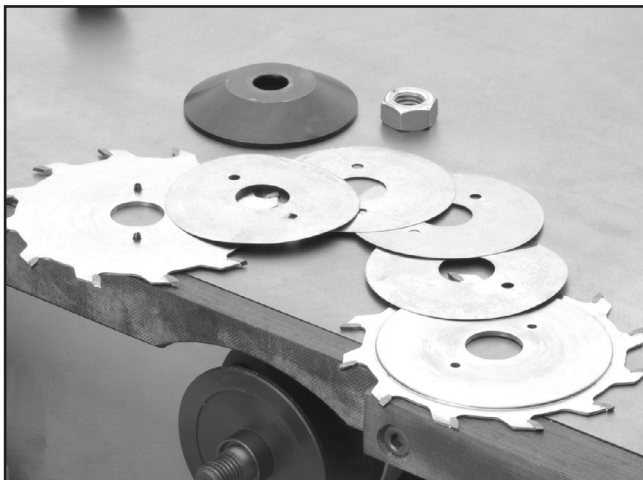
# Scoring Blade

Most scoring blade sets consist of an inner and outer blade and internal shims. The shims are provided so the scoring blade thickness can be adjusted to match the kerf thickness of the main blade. The requirements for the G0460/G0461 scoring blade are an 80mm outside diameter with a 20mm arbor hole.

**Components and Hardware Needed:** Qty  
Scoring Blade (Not Included) ..... 1

## To install the scoring blade:

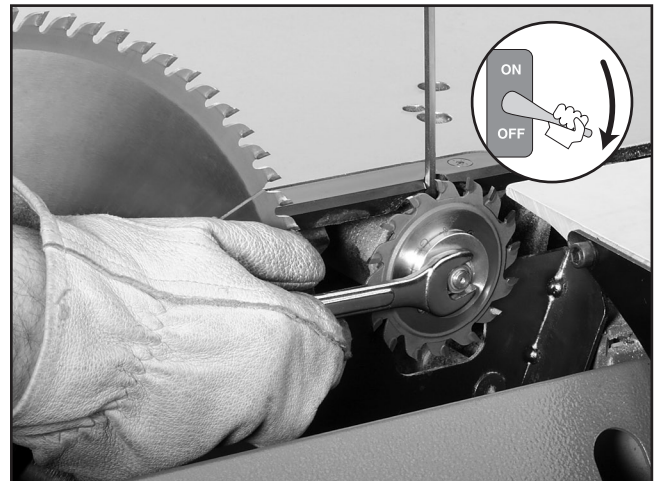
1. DISCONNECT SAW FROM POWER!
2. Move the blade tilt to 0° (blade 90° to table) and lower the main blade all the way down.
3. Slide the table all the way forward to access the blade arbor, loosen the flange bolt securing the lower blade guard, slide the flange bolt up, and pull open the lower blade guard.
4. Measure the thickness of the main blade (at the carbide tips). Use the shims that came with the scoring blade set (**Figure 38**) to stack the scoring blade to the same thickness as the main blade.



**Figure 38.** Typical scoring blade with shims.

5. Install the blade set with the teeth facing the opposite direction as the main blade, then re-install the arbor flange and the arbor nut.
6. Place a hex wrench in the hole in the arbor and use the arbor wrench to tighten the arbor nut as shown in **Figure 39**.

**Note:** The arbor nut has right-hand threads and tightens by turning clockwise.



**Figure 39.** Installing the scoring blade.

7. Move the lower blade guard back into its original position and lock it in place.

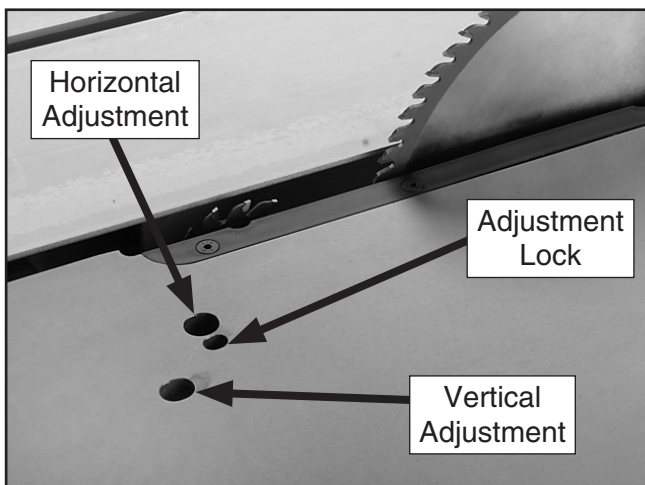


# Aligning Blades

The scoring blade must be aligned with the main blade to ensure satisfactory cutting results.

## To align the blades and riving knife:

1. DISCONNECT SAW FROM POWER!
2. Move the blade tilt to 0° (blade 90° to table), and raise the main blade all the way up.
3. Unlock the scoring blade adjustment using a hex wrench in the adjustment lock socket (**Figure 40**) and raise the blade to its highest point using a hex wrench in the vertical adjustment socket.



**Figure 40.** Scoring blade adjustment controls.

4. Remove the stop screw from the round rail and move the rip fence against the blade as shown in **Figure 41**.



**Figure 41.** Fence against blade as a guide for aligning the scoring blade.

5. Use the adjustment controls to move the scoring blade so that the rip fence can touch both the scoring blade and the main blade.
6. Install the riving knife, making sure it is aligned with the blades.

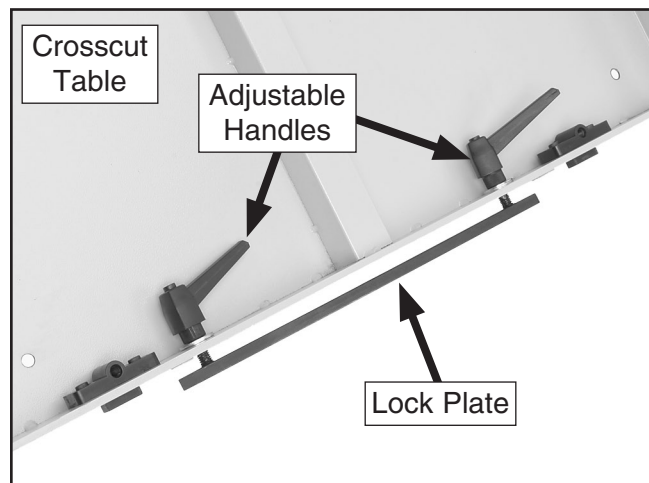
# Crosscut Table

Components and Hardware Needed:	Qty
Crosscut Table .....	1
Lock Plate.....	1
Adjustable Handles M10-1.5.....	1
Flat Washers 10mm .....	2

## To install the crosscut table:

1. Thread the adjustable handles, with 10mm flat washers, two or three turns onto the studs in the lock plate, as shown in **Figure 42**.

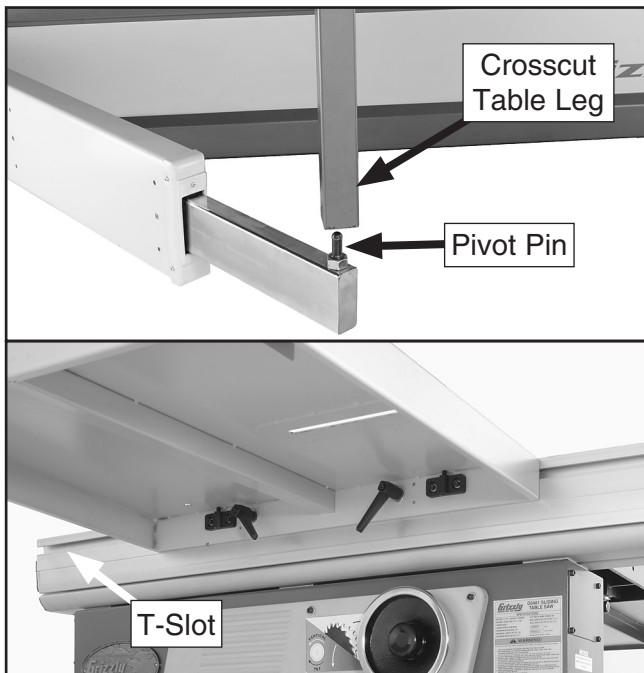
**Note:** The lock handles have a ratcheting action. Disengage them by pulling back on the handle. When held back (disengaged), the handles will rotate in either direction without turning the threads. When you let go of the handles, the internal spring will automatically engage them again.



**Figure 42.** Adjustable handles threaded into lock plate to prepare for crosscut table installation.



- Slide the lock plate into the T-slot in the side of the sliding table.
- With the help of an assistant, place the crosscut table on the pivot pin of the swing arm and over the studs of the lock plate (see **Figure 43**).



**Figure 43.** Installing the crosscut table.

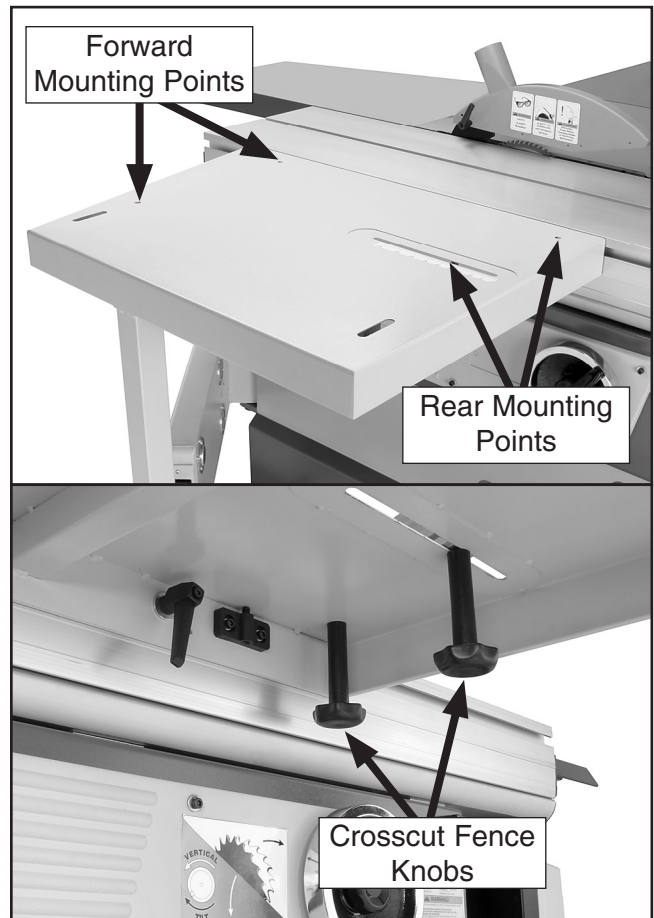
- Lock the crosscut table in place with the adjustable handles.

## Crosscut Fence

Components and Hardware Needed:	Qty
Crosscut Aluminium Fence .....	1
Long Knobs M10-1.5.....	2
Flip Stops .....	2

### To install the crosscut fence:

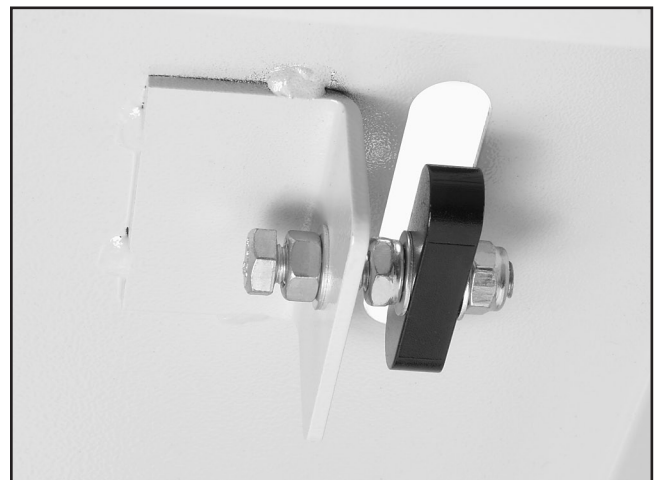
- Insert the T-bolts in the areas indicated in **Figure 44**, depending on whether or not you want the crosscut fence in the forward or rear position. (Refer to **Page 36** for more details.)



**Figure 44.** Crosscut fence mounting.

- Place a framing square along the edge of the sliding table and use the crosscut fence adjustment screw (**Figure 45**) to align the fence perpendicular to the sliding table.

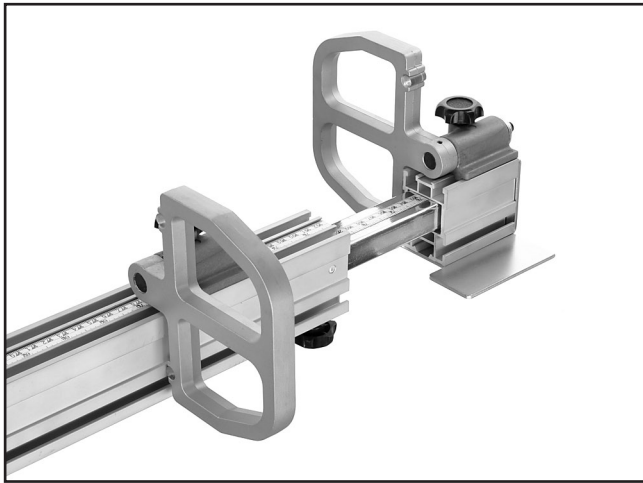
**Note:** Refer the instructions on **Page 47** for additional details on making the fence perpendicular.



**Figure 45.** Crosscut fence adjustment screw.



3. Thread the knobs onto the T-bolts to secure the crosscut fence.
4. Unlock the fence extension and slide the flip stops into the fence as shown in **Figure 46**.



**Figure 46.** Stop block installation.

## Fence Scale Alignment

Before operation, align the 0" mark on the rip fence scale with the right side of the blade to ensure accurate measurements.

### To align the rip fence scale with the blade:

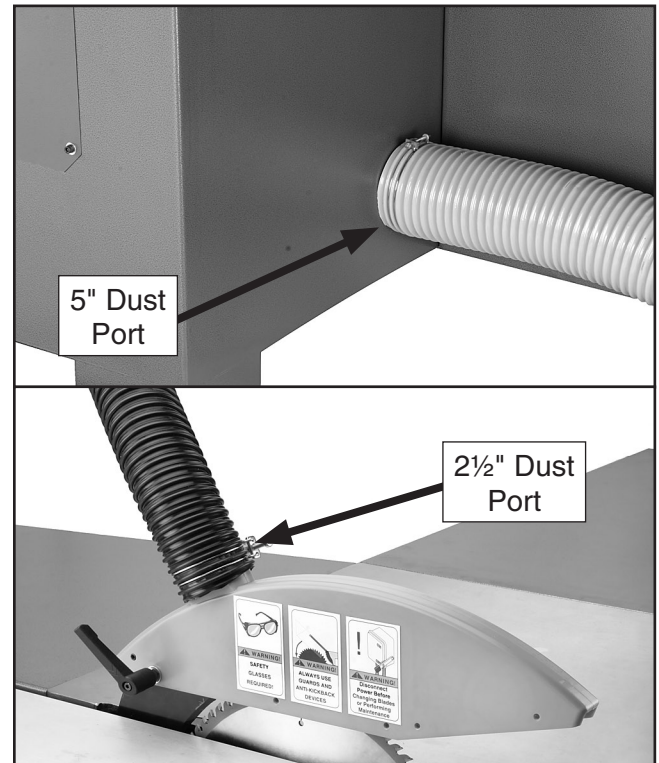
1. Move the blade tilt to 0° (blade 90° to table), and raise the main blade all the way up.
2. Remove the stop screw from the round rail and move the rip fence against the blade.
3. Loosen the cap screws securing the scale.
4. Slide the fence scale to line up the first mark on the scale with the left edge of the rip fence and tighten the cap screws.
5. Slide the fence away from the blade and replace the stop screw.

## Dust Collection

Components and Hardware Needed:	Qty
Blade Guard Dust Hood .....	1
Flat Washer 8mm .....	1
Adjustable Handle M8-1.25 x 28 .....	1
5" Dust Hose (not included) .....	1
5" Hose Clamp (not included) .....	2
2½" Dust Hose (not included) .....	1
2½" Hose Clamp (not included) .....	2
Dust Collection System (not included) .....	1

### To connect the dust ports to a dust collector:

1. Run a 5" hose from the dust collector to the dust port located under the saw table (**Figure 47**) and secure it with hose clamps.



**Figure 47.** Dust port locations.

2. Install the blade guard/dust hood on the ripping knife with the adjustable handle and flat washer as shown in **Figure 47**.
3. Run a 2½" hose from the dust collector to the blade guard port (**Figure 47**) and secure it with hose clamps.





# Test Run

---

Once the assembly is complete, test run your machine to make sure it runs properly and is ready for regular operation.

The test run consists of verifying the following: 1) The motor powers up and runs correctly and 2) the stop button safety feature works correctly. For the G0461 only, you must also make sure that the motor turns the correct direction.

If, during the test run, you cannot easily locate the source of an unusual noise or vibration, stop using the machine immediately, then review **Troubleshooting** on **Page 43**.

If you still cannot remedy a problem, contact our Tech Support at (570) 546-9663 for assistance.

## **WARNING**

**Before starting the saw, make sure you have performed the preceding assembly and adjustment instructions, and you have read through the rest of the manual and are familiar with the various functions and safety features on this machine. Failure to follow this warning could result in serious personal injury or even death!**

### To test run the machine:

1. Make sure you have read the safety instructions at the beginning of the manual and that the machine is setup properly.
2. Make sure all tools and objects used during setup are cleared away from the machine.
3. Connect the machine to the power source.
4. Push the stop button in, then twist it clockwise so it pops out.

5. Verify that the machine is operating correctly by turning it **ON**.

—When operating correctly, the machine runs smoothly with little or no vibration or rubbing noises.

—Investigate and correct strange or unusual noises or vibrations before operating the machine further. Always disconnect the machine from power when investigating or correcting potential problems.

6. Turn the machine **OFF**.

7. Push the STOP button.

8. Press the green ON button. The machine should not start.

—If the machine does not start, the STOP button safety feature is working correctly.

—If the machine does start (with the stop button pushed in), immediately disconnect power to the machine. The STOP button safety feature is not working correctly. This safety feature must work properly before proceeding with regular operations. Call Tech Support for help.

9. FOR G0461 ONLY: Verify that the main blade is turning the correct direction by starting the motor, then stopping the motor while watching the main blade come to a stop.

—If the main blade turns clockwise (as standing in front of the machine), it is turning in the correct direction.

—If the main blade turns counterclockwise (toward the rear of the machine), it is turning in the wrong direction. Stop the machine, disconnect it from power, then exchange any two of the three power wires in the terminal box. For additional help with this, contact our Technical Support Department at (570) 546-9663.

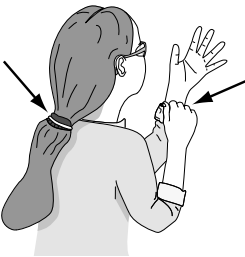
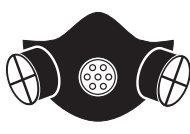


# SECTION 4: OPERATIONS

## Operation Safety

### **!WARNING**

Damage to your eyes, lungs, and ears could result from using this machine without proper protective gear. Always wear safety glasses, a respirator, and hearing protection when operating this machine.



### **!WARNING**

Loose hair and clothing could get caught in machinery and cause serious personal injury. Keep loose clothing and long hair away from moving machinery.

### **NOTICE**

If you have never used this type of machine or equipment before, WE STRONGLY RECOMMEND that you read books, trade magazines, or get formal training before beginning any projects. Regardless of the content in this section, Grizzly Industrial will not be held liable for accidents caused by lack of training.

## Operation Tips

Your safety is important. The tips below are intended to supplement **SECTION 1: SAFETY**. But remember, no safety list can be comprehensive of every situation. The operator is ultimately responsible for their own safety, as well as the safety of bystanders. Every cutting operation is uniquely different and may require safety equipment or safety procedures not mentioned in this manual.

**Please follow these tips EVERY time you use your saw:**

- Stand to the left of the blade line-of-cut when operating the saw to reduce your risk of injury if a kickback occurs.
- Turn **OFF** the saw and allow the blade to come to a complete stop before removing the cut-off piece.
- Make sure that the riving knife is always aligned with the main blade before cutting.
- Always position the blade guard to the correct height above the workpiece.
- Carefully plan each cutting operation to avoid injuries.
- When you release the sliding table lock, make sure that the knob is positioned so that it will not lock the table during a cut.

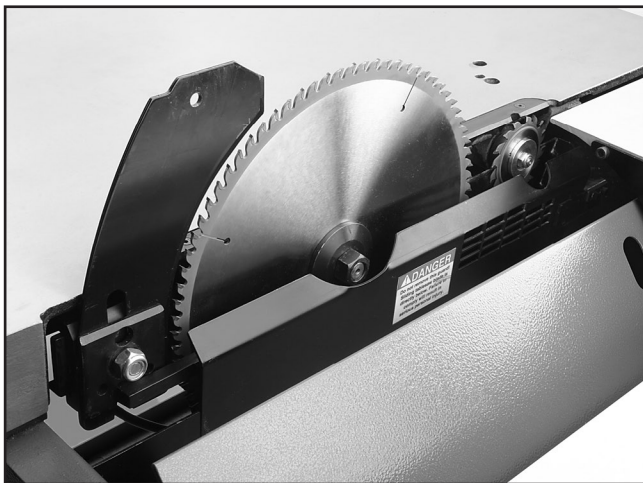


# Changing Blades

The Model G0460/G0461 performs best when high quality, sharp blades are used. Therefore, whenever the blades start to get dull, we recommend that you have them resharpened or replaced with a new blade.

## To change the blades:

1. DISCONNECT SAW FROM POWER!
2. Move the blade tilt to 0° (blade 90° to table) and raise the main blade as high as it will go.
3. Slide the table all the way forward to access the blade arbor, loosen the bolt securing the lower blade guard, slide the bolt up, and pull open the lower blade guard shown in **Figure 48**.



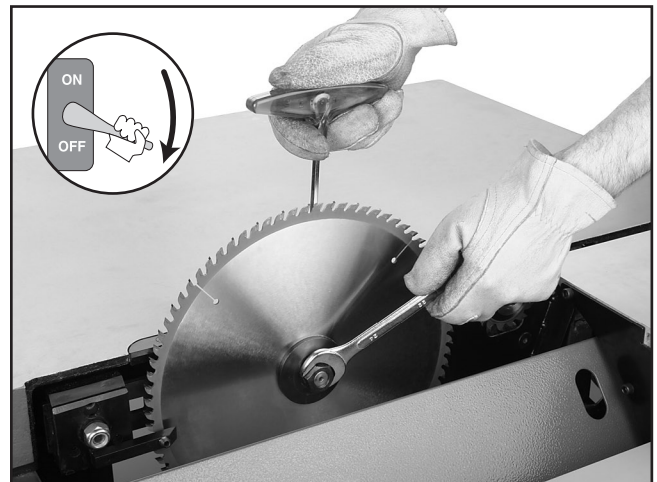
**Figure 48.** Internal blade guard exposed.

4. Place a hex wrench in the hole in the arbor of the blade you wish to change to prevent the arbor from rotating, then use the arbor wrench to remove the arbor nut and flange.

**Note:** The arbor nut on the main blade has left hand threads and loosens by turning clockwise. The arbor nut on the scoring blade has right hand threads and loosens by turning counterclockwise.

5. When replacing the scoring blade, measure the main blade carbide teeth and stack the scoring blade with shims to match this thickness.
6. Install the main blade with the teeth facing to the right (as standing in front of the machine), and install the scoring blade with the teeth facing the back of the saw.
7. Re-install the arbor flange and the arbor nut, then tighten them against the blade as shown in **Figure 49**.

**Note:** Wear gloves to protect your hands when installing or removing blades.



**Figure 49.** Replacing the main blade.

8. Position the riving knife about 3mm or 1/8" away from the nearest carbide tooth on the main blade.

**Note:** For a quick gauge, use the 3mm hex wrench to find the correct spacing between the blade and the riving knife.

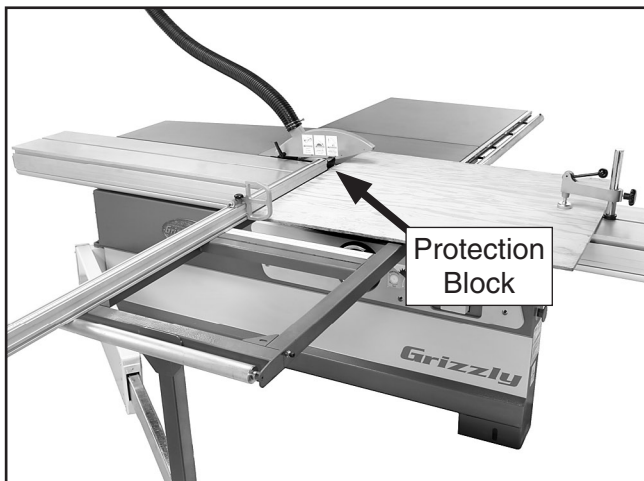
9. Align the scoring blade to the main blade as described in the **Aligning Blade** instructions on **Page 28**.
10. Align the riving knife with the blades as instructed on **Page 25**.
11. Move the lower blade guard back into its original position and lock it in place with the bolt.



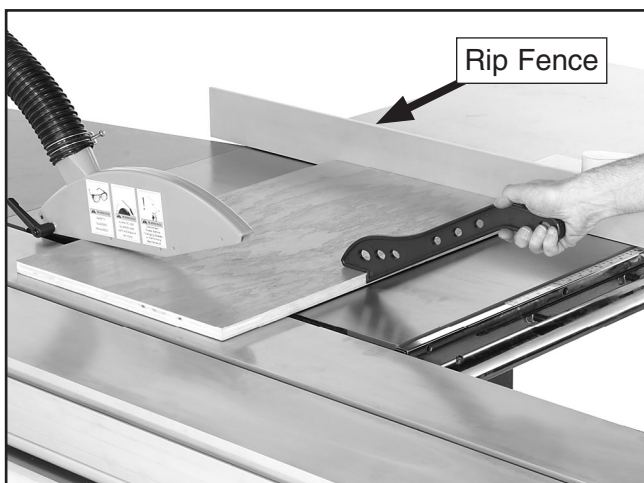
# Rip Cutting

The Model G0460/G0461 easily rips 4' x 8' panels (**Figure 50**). The sliding table removes the burden of sliding a large and heavy panel over a stationary table surface.

This saw also can rip smaller boards using the rip fence in the same manner as a traditional table saw (**Figure 51**). Smaller, lighter boards are easier to slide across the stationary cast iron table surface to the right of the saw blade.



**Figure 50.** Typical rip cutting operation with a sliding table.



**Figure 51.** Traditional rip cutting.

## Rip cutting with the sliding table:

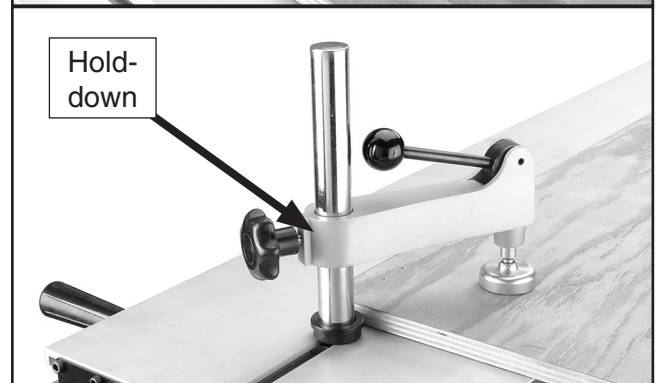
1. Install the crosscut fence, align the fence to 90°, and adjust it as instructed on **Page 47**.

2. Slide the protection block on the end of the crosscut fence against the blade teeth to calibrate the scale, then tighten the lock knob.

**Note:** *The scale will not be accurate if the protection block has been cut.*

3. Set a flip stop to the desired width-of-cut.
4. Position the blade guard to the correct height for your workpiece.
5. Load the workpiece onto the table saw. The setup should look similar to **Figure 50**.
6. When ripping irregular shaped stock, wedge the leading edge under the edge shoe (**Figure 52**), slide the hold-down into place as shown in **Figure 52**, and clamp the stock firmly.

**Note:** *DO NOT use the edge shoe for ripping warped or twisted boards. The tension that causes warps and twists can cause the board to spring free from the edge shoe and hold-down during a cut.*



**Figure 52.** Edge shoe and hold-down placement.

7. Take all the necessary safety precautions, then perform the cutting operation.



## Rip cutting with the rip fence:

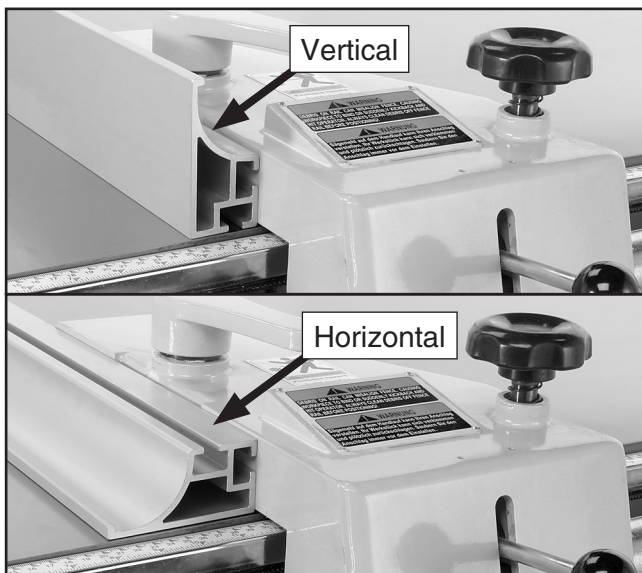
1. Remove the crosscut fence.
2. Use the table lock (**Figure 53**) to lock the sliding table into a stationary position. (To lock the sliding table, you have to engage the lock and center the table in front of the machine. The table will automatically lock when it is in the correct position.)



**Figure 53.** Sliding table lock.

3. Place the rip fence in the vertical position for larger workpieces or in the horizontal position for angled cuts and operations with thin workpieces (see **Figure 54**).

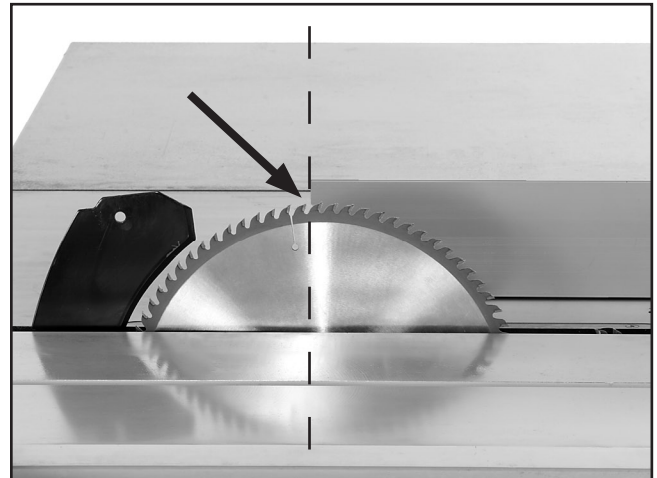
**Note:** Refer to **Figure 29** on **Page 24** for instructions on installing/removing the rip fence.



**Figure 54.** Rip fence positions.

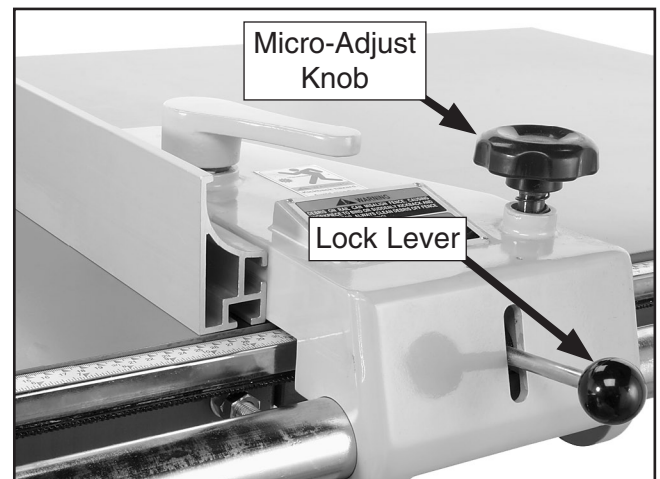
4. Lift the lock lever and position the rip fence to approximately the desired width-of-cut.
5. Slide the leading end of the rip fence so it is even with the center of the main saw blade as shown in **Figure 55**.

**Note:** This technique allows the finished cut-off piece to “fall” away from the blade when the cutting operation is complete, reducing the possibility of kickback.



**Figure 55.** Rip fence even with center of blade (blade guard removed for clarity).

6. Push down on the rip fence micro-adjust knob (**Figure 56**) and turn it to precisely set the width-of-cut.



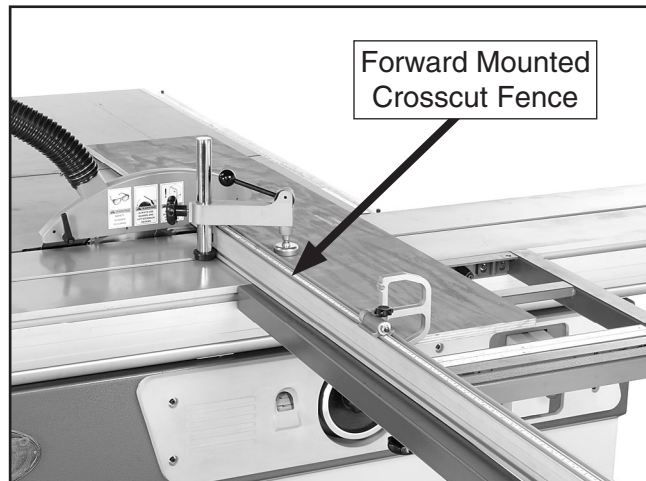
**Figure 56.** Rip fence micro-adjusting controls.

7. Push down the lock lever, then perform the cutting operation.



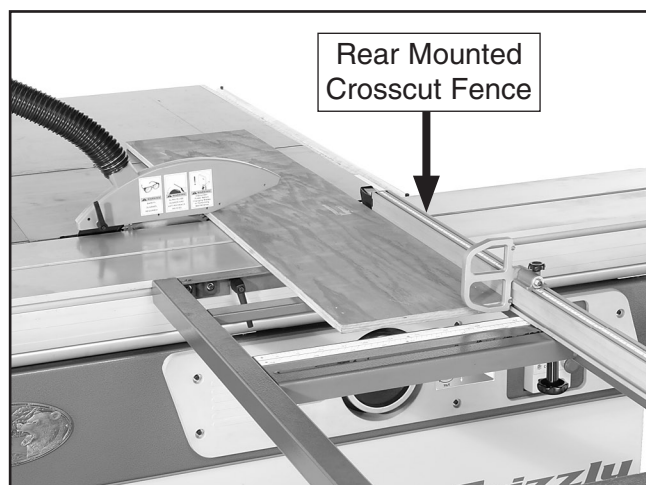
# Crosscutting

The Model G0460/G0461 can crosscut 4' x 8' panels with the fence in the forward or rear position, although it is easier to load full size panels with the crosscut fence mounted in the forward position (see **Figure 57**).



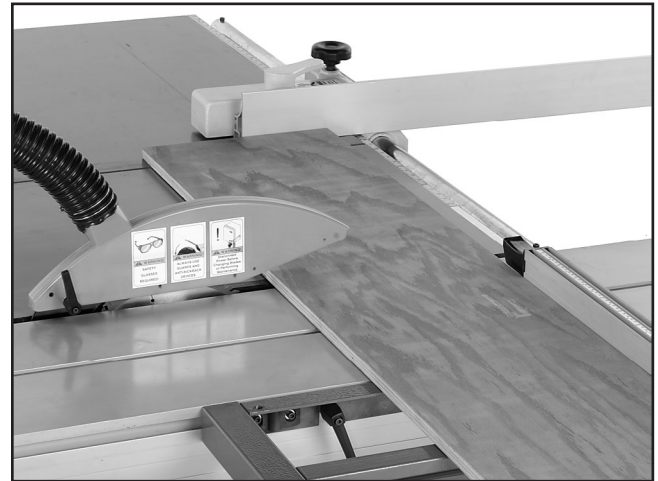
**Figure 57.** Typical crosscutting operation with the crosscut fence in the forward position.

Mounting the crosscut fence in the rear position (**Figure 58**) gives greater stability for crosscutting smaller panels.



**Figure 58.** Typical crosscutting operation with the crosscut fence in the rear position.

This machine can also crosscut workpieces while using the rip fence as a cut-off gauge (**Figure 59**).



**Figure 59.** Crosscutting workpieces using the rip fence as a cut-off gauge.

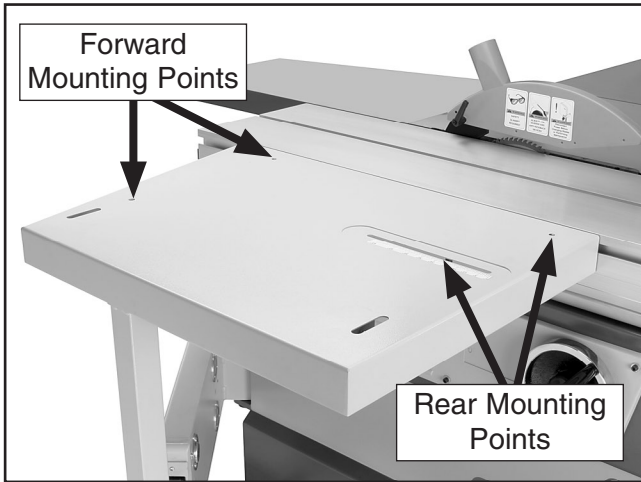
Determine which cutting operation will be best suited for the workpiece to be crosscut.

- If you will be crosscutting full size panels, then skip ahead to “**Crosscutting full size panels**” on the next page.
- If you will be crosscutting smaller panels, then skip ahead to “**Crosscutting smaller panels**” on the next page.
- If you will be crosscutting workpieces using the rip fence as a cut-off gauge, then skip ahead to “**Crosscutting using the rip fence as a cut-off gauge**” on the next page.



## Crosscutting full size panels:

1. Install the crosscut fence in the forward mounting points shown in **Figure 60** and lock it in place.



**Figure 60.** Crosscut fence mounting points.

2. Check to make sure the fence is at 90° and adjust it as described in **Squaring Crosscut Fence to Blade** on **Page 47** if necessary.
3. Set either flip stop to the desired width-of-cut.
4. Load the workpiece onto the table saw. The setup should look similar to **Figure 57**.
5. Once all the necessary safety precautions have been taken, perform the cutting operation.

## Crosscutting smaller panels:

1. Install the crosscut fence in the rear mounting points shown in **Figure 60** and lock it in place.
2. Check to make sure the fence is at 90° and adjust it as described in **Squaring Crosscut Fence to Blade** on **Page 47** if necessary.
3. Set either flip stop to the desired width-of-cut.

4. Load the workpiece onto the table saw. The setup should look similar to **Figure 58**.
5. Once all the necessary safety precautions have been taken, perform the cutting operation.

## Crosscutting using the rip fence as a cut-off gauge:

1. Install the crosscut fence in the rear mounting points shown in **Figure 60** and lock it in place.
2. Check to make sure the fence is at 90° and adjust it as described in **Squaring Crosscut Fence to Blade** on **Page 47** if necessary.
3. Position the rip fence for the desired width.
4. Load the workpiece onto the table saw. The setup should look similar to **Figure 59**.
5. Slide the leading end of the rip fence behind the back edge of the blade as shown in **Figure 61**.



**Figure 61.** Correct rip fence position when using it as a cut-off gauge.

6. Take all the necessary safety precautions, then perform the cutting operation.



# Miter Cutting

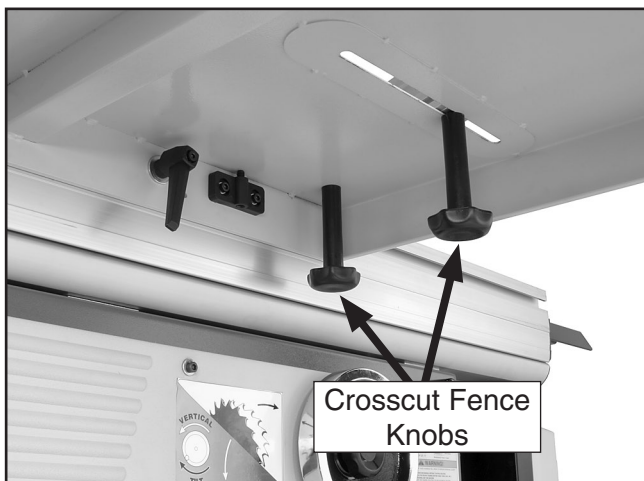
The miter fence allows miter cuts from 0° to 90°. The table mounted miter scale has a resolution of 1°.

## To perform a miter cut:

1. Slide the crosscut table to the front edge of the sliding table and lock it in place.
2. Install the fence as shown in **Figures 62 & 63** for angled cuts.

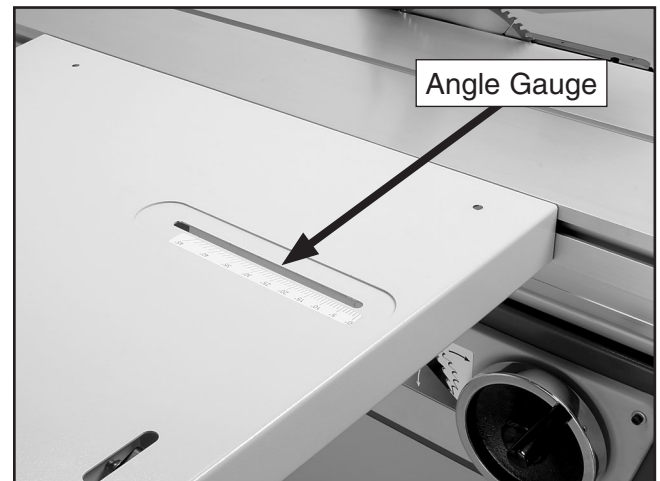


**Figure 62.** Fence set-up for angled cuts.



**Figure 63.** Fence installed (underside view).

3. Set the fence to the desired angle using the crosscut table angle gauge and lock the angle with the crosscutting fence knob (see **Figure 64**).



**Figure 64.** Crosscut table angle gauge.

4. Position the flip stop according to the length of the workpiece you want to cut off to the left of the blade.
5. Load the workpiece onto the table saw. The setup should look similar to **Figure 65**.



**Figure 65.** Example of miter cutting operation.

6. Once all the necessary safety precautions have been taken, perform the cutting operation.





# SECTION 5: ACCESSORIES

## H3308—SHOP FOX® Push Stick

Measuring 13½" overall, this push stick allows the operator to keep their hands at a safe distance away from the blade or cutter.



Figure 66. H3308 SHOP FOX® Push Stick.

## G3445—Precision Saw Tool

This high impact plastic Saw Aid™ quickly measures blade height and angle and can also serve as a solid push stick. Includes a graduated ruler guide and center finder.

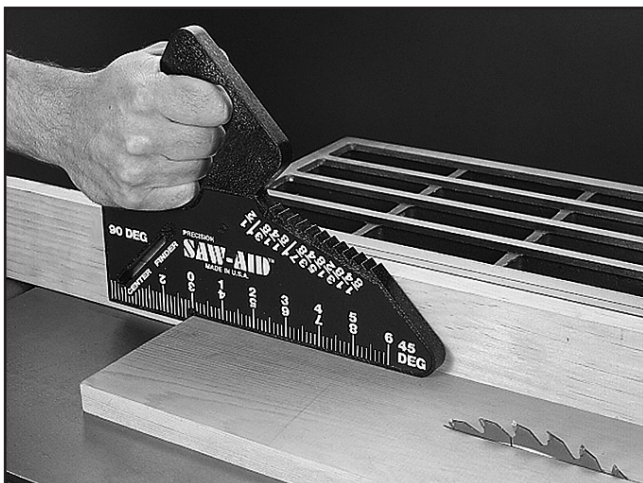


Figure 67. G3445 Precision Saw Tool.

## H3771—Blade Loc®

This simple tool secures the blade during blade changes, keeping your hands safe and your expensive blade from being damaged.



Figure 68. H3771 Blade Loc®.

## G7581—Superbar™

## G7582—Master Plate

The miter slot mounted Superbar™ will align, tune and calibrate your tablesaw to within ±0.001 in just minutes. Replace your tablesaw blade when calibrating the double disk ground Master Plate for a precision measurement, with no runout!

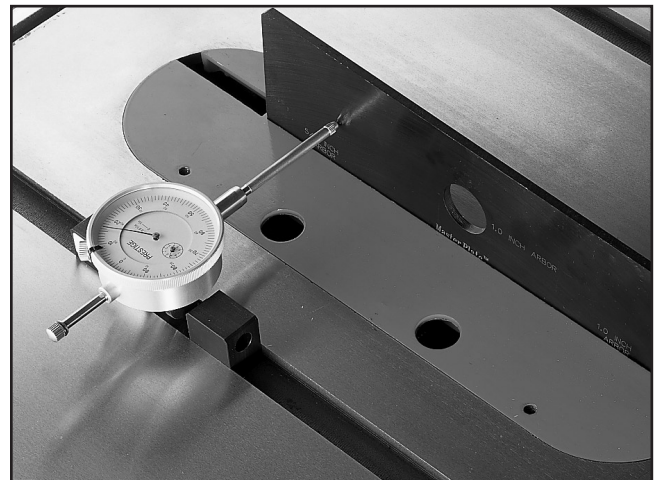


Figure 69. Superbar™ and Master Plate.

**Call 1-800-523-4777 To Order**



- G7984—Face Shield
- H1298—Dust Sealed Safety Glasses
- H1300—UV Blocking, Clear Safety Glasses
- H2347—Uvex® Spitfire Safety Glasses
- H0736—Shop Fox® Safety Glasses

Safety Glasses are essential to every shop. If you already have a pair, buy extras for visitors or employees. You can't be too careful when it comes to shop safety!

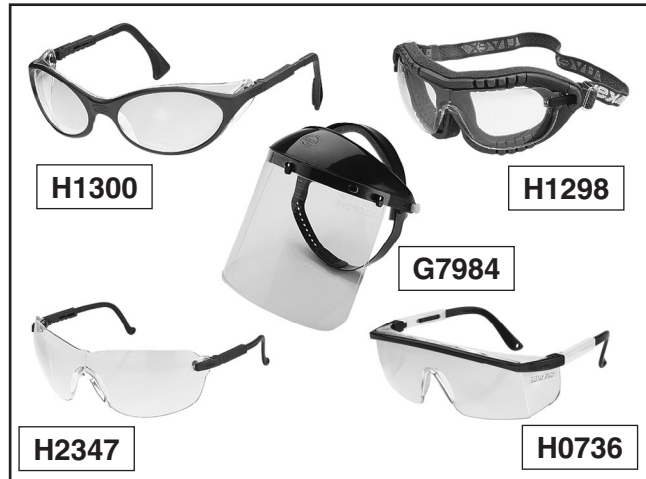


Figure 70. Our most popular safety glasses.

- G5562—SLIPIT® 1 Qt. Gel
- G5563—SLIPIT® 12 oz Spray
- G2871—Boeshield® T-9 12 oz Spray
- G2870—Boeshield® T-9 4 oz Spray
- H3788—G96® Gun Treatment 12 oz Spray
- H3789—G96® Gun Treatment 4.5 oz Spray



Figure 71. Recommended products for protecting unpainted cast iron/steel part on machinery.

**Carbide-Tipped Saw Blades (ATB)**  
**G4808—12" Ripping, 40T**  
**G4809—12" General Purpose, 60T**  
**G4810—12" Fine Finishing/Cabinet Work, 80T**  
 These ATB blades are manufactured to close tolerances and are fully balanced before leaving the factory. All the carbide-tipped teeth are precisely ground to give a smooth cut every time. The pattern of the teeth is alternate top bevel and the saw kerf is approx. 1/8". These blades have proven themselves in thousands of cabinet shops around the country. Manufactured for heavy-duty use.



Figure 72. Carbide-tipped saw blades.

**H6460—12 Tooth Scoring Blade Set**  
 The scoring blade set consists of an inner and outer blade and four internal shims. Two shims are 0.008" thick and two are 0.004". The shims are provided so the scoring blade set can match the kerf thickness of the main blade.

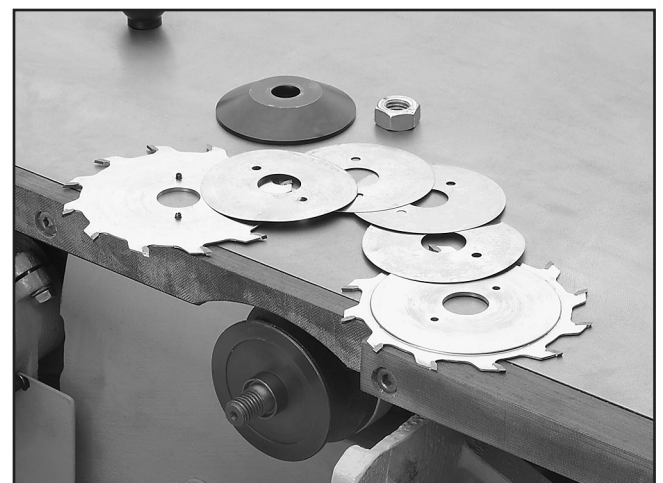


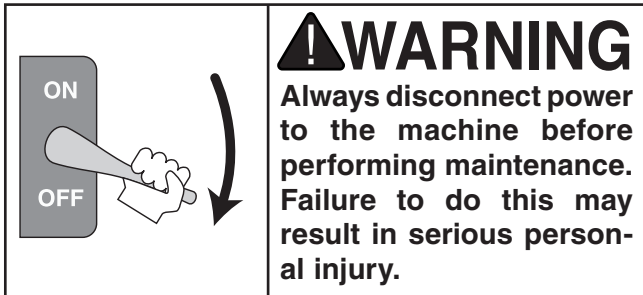
Figure 73. H6460 Scoring Blade Set.



# SECTION 6: MAINTENANCE

---

---



## Schedule

---

For optimum performance from your machine, follow this maintenance schedule and refer to any specific instructions given in this section.

### Daily Check

- Loose mounting bolts.
- Worn or damaged saw blade.
- Worn or damaged switches or wires.
- Any other unsafe condition.

### Weekly Maintenance

- Clean sliding table surface and grooves.
- Clean the cast iron saw table.
- Clean the sliding table roller guideways.
- Clean the rip fence and sliding grooves.
- Clean the rip fence bracket.

### Monthly Check

- Clean/vacuum dust buildup from inside cabinet and off motor.
- V-belt tension, damage, or wear. (Adjust V-belt tension after the initial 10 hours of operation.)

## Cleaning

---

---

Cleaning the Model G0460/G0461 is relatively easy. Vacuum excess wood chips and sawdust, and wipe off the remaining dust with a dry cloth.

Use compressed air to blow dust from between the two sections of the sliding table. If any resin has built up, use a resin dissolving cleaner to remove it.

Never use water to clean the machine. Unpainted cast iron or other metal parts will quickly rust.

Treat all unpainted cast iron and steel with a non-staining lubricant or metal protectant after cleaning.

## Unpainted Cast Iron

---

---

Protect the unpainted cast iron surfaces on the table by wiping the table clean after every use—this ensures moisture from wood dust does not remain on bare metal surfaces.

Keep tables rust-free with regular applications of products like G96® Gun Treatment, SLIPIT®, or Boeshield® T-9 (see **SECTION 5: ACCESSORIES** on **Page 39** for more details).



# Lubrication

The bearings are sealed and pre-lubricated and require no lubrication during their usable life. However, your saw components will operate at their best if the bearing surfaces are kept clean—this is especially important for the trunnion bearings.

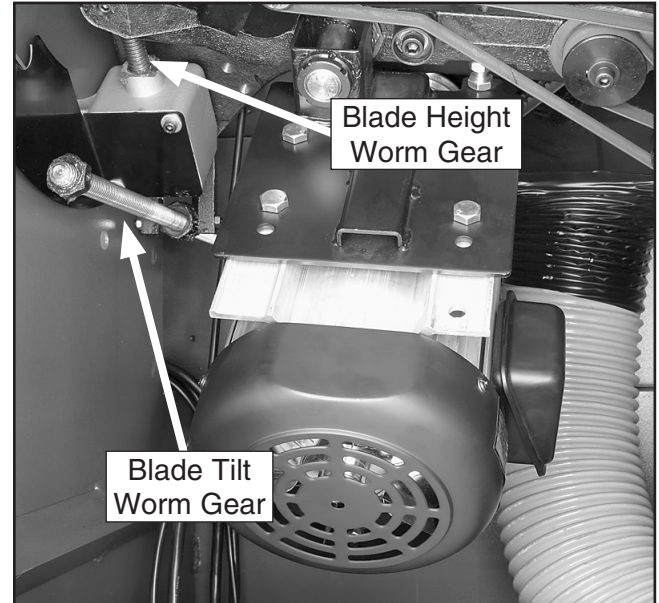
Lubricate the areas indicated below every 6-12 months, depending on frequency of use.

- **Sliding table ways.** Spray or wipe on a light machine oil or lubricant (such as Boeshield T9®) along the entire length of the steel rods (see **Figure 74**).



**Figure 74.** Sliding table ways.

- **Blade height and tilt worm gears.** Lubricate with an automotive wheel bearing grease (see **Figure 75**).



**Figure 75.** Gear lubrication.

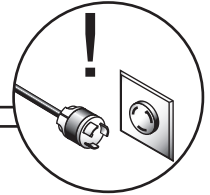
- **Other pivot points.** All other pivot points under the table should be lubricated with 6 or 7 drops of light machine oil.



# SECTION 7: SERVICE

Review the troubleshooting and procedures in this section to fix or adjust your machine if a problem develops. If you need replacement parts or you are unsure of your repair skills, then feel free to call our Technical Support at (570) 546-9663.

## Troubleshooting



### Motor & Electrical

Symptom	Possible Cause	Possible Solution
Machine does not start or a breaker trips.	<ol style="list-style-type: none"> <li>1. Start capacitor is at fault (G0460).</li> <li>2. Emergency stop push-button is engaged/faulty.</li> <li>3. Motor connection wired incorrectly.</li> <li>4. Thermal overload relay has tripped.</li> <li>5. Contactor not getting energized/has burnt contacts.</li> <li>6. Power supply switched OFF or is at fault.</li> <li>7. Blade guard limit switch engaged/at fault.</li> <li>8. Wiring is open/has high resistance.</li> <li>9. Motor is at fault.</li> </ol>	<ol style="list-style-type: none"> <li>1. Test/replace if faulty.</li> <li>2. Rotate clockwise slightly until it pops out/replace it.</li> <li>3. Correct motor wiring connections.</li> <li>4. Turn cut-out dial to increase working amps and push the reset pin. Replace if tripped multiple times (weak relay).</li> <li>5. Test for power on all legs and contactor operation. Replace unit if faulty.</li> <li>6. Ensure power supply is switch on; ensure power supply has the correct voltage.</li> <li>7. Move blade guard to the working position; replace faulty limit switch.</li> <li>8. Check for broken wires or disconnected/corroded connections, and repair/replace as necessary.</li> <li>9. Test/repair/replace.</li> </ol>
Machine stalls or is underpowered.	<ol style="list-style-type: none"> <li>1. Workpiece material is not suitable for this machine.</li> <li>2. Feed rate/cutting speed too fast for task.</li> <li>3. Run capacitor is at fault (G0460).</li> <li>4. Belt(s) slipping.</li> <li>5. Plug/receptacle is at fault.</li> <li>6. Motor is wired incorrectly.</li> <li>7. Pulley/sprocket slipping on shaft.</li> <li>8. Motor bearings are at fault.</li> <li>9. Machine is undersized for the task.</li> <li>10. Motor has overheated.</li> <li>11. Contactor not getting energized or has poor contacts.</li> <li>12. Motor is at fault.</li> </ol>	<ol style="list-style-type: none"> <li>1. Only cut wood products; make sure moisture content is below 20% and there are no foreign materials in the workpiece.</li> <li>2. Decrease feed rate/cutting speed.</li> <li>3. Test/repair/replace.</li> <li>4. Replace bad belt(s) as a matched set, align pulleys, and re-tension.</li> <li>5. Test for good contacts; correct the wiring.</li> <li>6. Correct motor wiring connections.</li> <li>7. Replace loose pulley/shaft.</li> <li>8. Test by rotating shaft; rotational grinding/loose shaft requires bearing replacement.</li> <li>9. Use sharp blade with lower TPI; reduce the feed rate/depth of cut.</li> <li>10. Clean off motor, let cool, and reduce workload.</li> <li>11. Test for power on all legs and contactor operation. Replace if faulty.</li> <li>12. Test/repair/replace.</li> </ol>



Symptom	Possible Cause	Possible Solution
Machine has vibration or noisy operation.	<ol style="list-style-type: none"> <li>1. Motor or component is loose.</li> <li>2. Motor fan is rubbing on fan cover.</li> <li>3. Blade is at fault.</li> <li>4. V-belt(s) worn or loose.</li> <li>5. Pulley is loose.</li> <li>6. Motor mount loose/broken.</li> <li>7. Arbor pulley is loose.</li> <li>8. Arbor bearings are at fault.</li> <li>9. Motor bearings are at fault.</li> <li>10. Blade is at fault.</li> </ol>	<ol style="list-style-type: none"> <li>1. Inspect/replace stripped or damaged bolts/nuts, and re-tighten with thread locking fluid.</li> <li>2. Replace dented fan cover; replace loose/damaged fan.</li> <li>3. Replace warped, bent, or twisted blade; resharpen dull blade.</li> <li>4. Inspect/replace belts with a new matched set.</li> <li>5. Realign/replace shaft, pulley, setscrew, and key as required.</li> <li>6. Tighten/replace.</li> <li>7. Retighten/replace arbor pulley with shaft and thread locking liquid.</li> <li>8. Replace arbor housing bearings; replace arbor.</li> <li>9. Test by rotating shaft; rotational grinding/loose shaft requires bearing replacement.</li> <li>10. Replace/resharpen blade.</li> </ol>
Main blade runs backwards (Model G0461 only).	<ol style="list-style-type: none"> <li>1. Two of the power wires are reversed (G0461).</li> </ol>	<ol style="list-style-type: none"> <li>1. Exchange wires R &amp; T in the terminal box (G0461).</li> </ol>

## Cutting Operations

Symptom	Possible Cause	Possible Solution
Workpiece has burned edges, binds, or kicks back.	<ol style="list-style-type: none"> <li>1. Sliding table is not parallel to blade.</li> <li>2. Riving knife is not aligned with the blade.</li> <li>3. Blade is warped.</li> </ol>	<ol style="list-style-type: none"> <li>1. Make sliding table parallel to the blade (<b>Page 48</b>).</li> <li>2. Shim the riving knife to align it with the main blade.</li> <li>3. Replace the blade.</li> </ol>
Workpiece has chip out on the bottom edge.	<ol style="list-style-type: none"> <li>1. Scoring blade height is incorrect.</li> <li>2. Scoring blade is not aligned with the main blade.</li> <li>3. Scoring blade kerf does not match the main blade.</li> </ol>	<ol style="list-style-type: none"> <li>1. Adjust the height of the scoring blade to approximately <math>\frac{5}{64}</math>" (2mm).</li> <li>2. Align the scoring blade (<b>Page 28</b>).</li> <li>3. Adjust the scoring blade kerf (<b>Page 27</b>).</li> </ol>
Sliding table saw does not cut square.	<ol style="list-style-type: none"> <li>1. Sliding table is not parallel to blade.</li> <li>2. Rip fence is not parallel to blade.</li> <li>3. Crosscut fence is not perpendicular to the blade.</li> </ol>	<ol style="list-style-type: none"> <li>1. Adjust the sliding table (<b>Page 48</b>).</li> <li>2. Adjust the rip fence (<b>Page 23</b>).</li> <li>3. Adjust the crosscut fence perpendicular to the blade (<b>Page 47</b>).</li> </ol>
Fence hits table top when sliding across table.	<ol style="list-style-type: none"> <li>1. Front rail is too low.</li> <li>2. Rip fence roller is too low.</li> </ol>	<ol style="list-style-type: none"> <li>1. Raise the rail (<b>Page 23</b>).</li> <li>2. Adjust the roller (<b>Page 23</b>).</li> </ol>
Blade does not reach 90°, or blade does not reach 45°.	<ol style="list-style-type: none"> <li>1. Blade stop nuts are out of adjustment.</li> </ol>	<ol style="list-style-type: none"> <li>1. Adjust the stop nuts (<b>Page 46</b>).</li> </ol>
The rip fence scale is not accurate.	<ol style="list-style-type: none"> <li>1. The rip fence scale is out of calibration or was not setup correctly.</li> </ol>	<ol style="list-style-type: none"> <li>1. Adjust the rip fence scale (<b>Page 30</b>).</li> </ol>
Tilt or blade height handwheels difficult to turn.	<ol style="list-style-type: none"> <li>1. Lock knob is tight.</li> <li>2. Gears caked with dust.</li> </ol>	<ol style="list-style-type: none"> <li>1. Release the lock knob.</li> <li>2. Clean out dust and grease the worm shafts.</li> </ol>

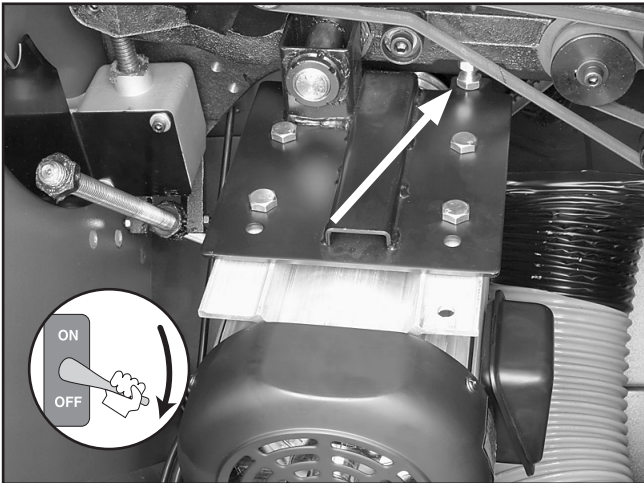


# Replacing Belts

To ensure optimal power transmission from the motor to the blades, the belts must be in good condition (free from cracks, fraying and wear) and operate under proper tension.

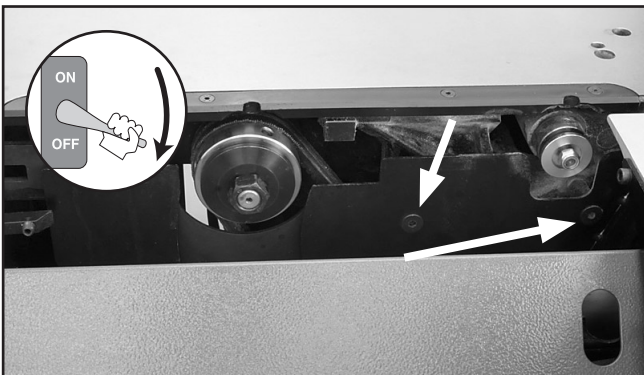
## To change the main blade arbor V-belt:

1. DISCONNECT SAW FROM POWER!
2. Move the blade tilt to 45°, lower the main blade all the way down, and remove the motor cabinet door.
3. Loosen the belt tension bolt (**Figure 76**) and pivot the motor up.



**Figure 76.** V-belt tension bolt.

4. Remove the screws that secure the lower blade guard (**Figure 77**) and set the guard in the bottom of the cabinet.



**Figure 77.** Lower blade guard removal.

5. Remove the old V-belt set and replace them with a new V-belt set.

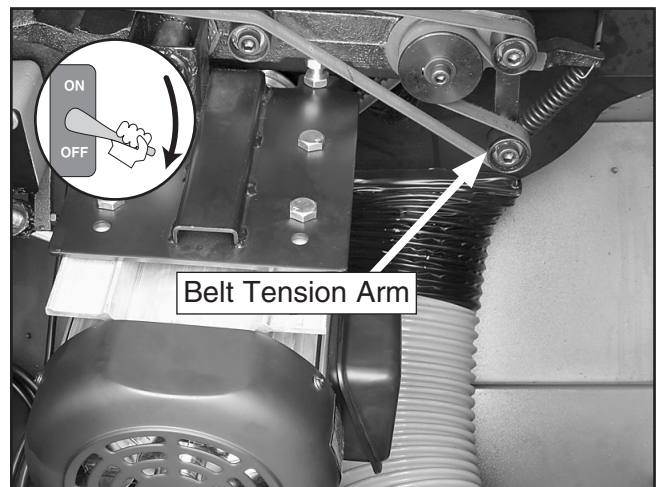
**Note:** *The motor V-belts should always be replaced as a matched set to ensure maximum belt longevity and power transmission.*

6. Tighten the tension bolt until the belts deflect between a ¼" and a ½" when pressed firmly in the center of each V-belt.
7. Replace the lower blade guard.
8. Close and secure the motor cabinet door.

**Note:** *Re-tension the new V-belts after the initial 10 hours of use.*

## To change the scoring blade arbor flat belt:

1. DISCONNECT SAW FROM POWER!
2. Move the blade tilt to 45°, raise the main blade all the way up, and open the motor cabinet door.
3. Rotate the belt tension arm shown in **Figure 78** and slide the flat belt off of the roller.



**Figure 78.** Scoring blade belt tension arm.

4. Remove the old flat belt and replace it with a new one. The belt tension arm will self-tension the belt.
5. Close and secure the motor cabinet door.

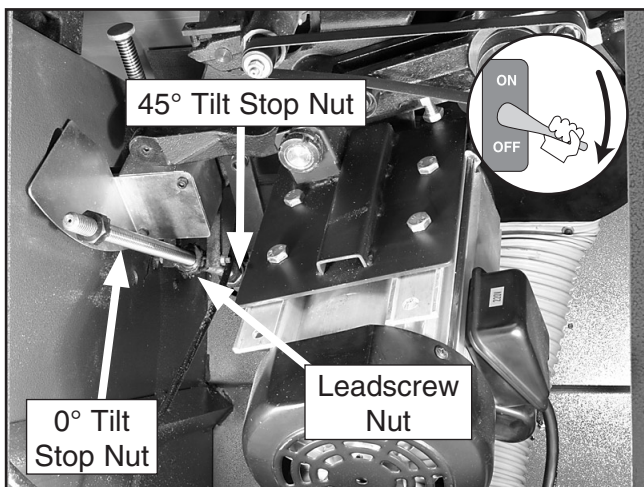


# Blade Tilt

The blade tilt is calibrated at the factory, but can be adjusted if it changes during the life of the machine.

## To calibrate the blade tilt:

1. DISCONNECT SAW FROM POWER!
2. Move the blade tilt to 0° according to the gauge, and raise the main blade as high as it will go.
3. Place a machinist's square on the table surface and between the blade teeth. Inspect for gaps between the blade and the square.
4. If a gap exists at either the top or bottom of the square, loosen the set screw in the 0° tilt stop nut shown in **Figure 79**.



**Figure 79.** Blade tilt stop nuts.

5. Turn the handwheel until the blade and square are flush from top to bottom.
6. Snug the 0° tilt stop nut against the leadscrew nut and tighten the set screw.
7. Recheck the blade with the square to ensure the nut has not been over-tightened.
8. Adjust the blade angle until you hit the 45° positive stop. Check the bevel with an adjustable square set to 45°.
9. If variations exist, loosen the set screw in the 45° tilt stop nut (**Figure 79**) and adjust the stop nut until the blade and square match.
10. Tighten the set screw and recheck the bevel by adjusting the blade tilt to 0°, then back to 45°.
11. Check the scale for accuracy at 45° and 0°.

—If the scale reads 45° when the blade is at 45° and 0° when the blade is at 90° to the table, it is accurate.

—If the scale reading does not match the blade angle, move the tilt angle to 0° and adjust the pointer on the scale to match the reading.



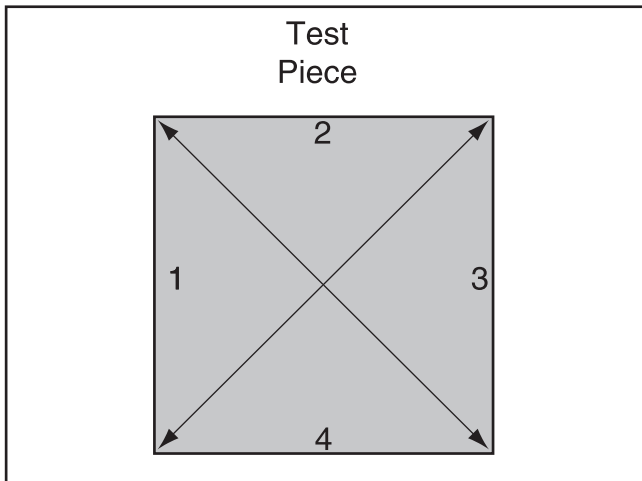


# Squaring Crosscut Fence to Blade

Squaring the crosscut fence to the blade ensures that cuts made with the crosscut fence will be square. This procedure consists of cutting a piece of scrap plywood five times, then adjusting the fence as necessary.

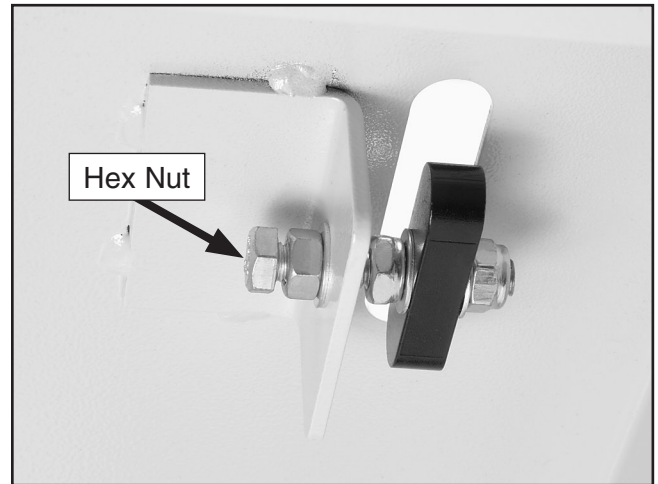
## To square the crosscut fence with the blade:

1. Make sure the blade is parallel with the sliding table.
2. Prepare the scrap test piece by numbering all four sides as shown in **Figure 80**.



**Figure 80.** Fence adjustment test piece.

3. Use the crosscut fence to cut  $\frac{1}{2}$ " off of each side of the test piece, then cut side 1 again (make 5 cuts total).
4. Measure the test piece diagonally from corner-to-corner as shown in **Figure 80**.  
—If both measurements are not within  $\frac{1}{16}$ ", then the crosscut fence needs to be adjusted. Proceed to **Step 5**.  
—If both measurements are within  $\frac{1}{16}$ " then you are finished with this procedure.
5. Loosen the hex nut shown in **Figure 81** and rotate the hex bolt to square the crosscut fence.



**Figure 81.** Crosscut fence adjustment cam.

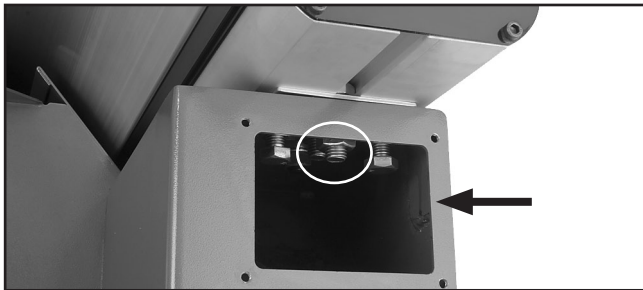
6. Tighten the hex nut and repeat **Steps 3-6**.



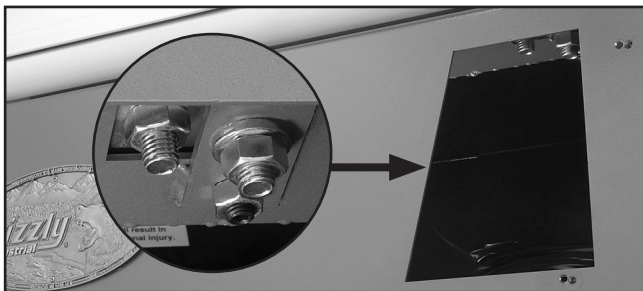
# Sliding Table Parallelism

To adjust the sliding table parallel with the main blade:

1. Move the blade tilt to  $0^\circ$  (blade  $90^\circ$  to table), and raise the main blade as high as it will go.
2. Loosen the sliding table mounting nuts (refer to **Figures 82–84**).



**Figure 82.** Access panel (left side).



**Figure 83.** Access panel (center).



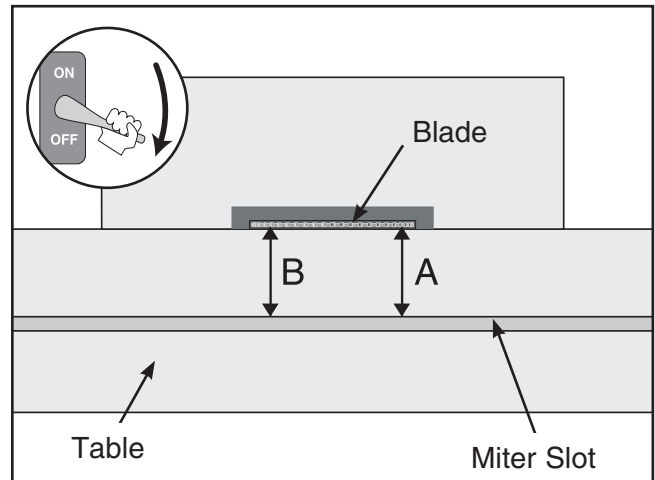
**Figure 84.** Access panel (right side).

3. Make a mark near the edge of the blade with a felt tip pen. This will allow you to take your measurements from the exact same place on the blade.

4. Using an adjustable square or a dial indicator, measure the distance (A) between the miter slot and the front of the blade as shown in **Figure 85**.

**Note:** Use a dial indicator for the most accurate results.

5. Rotate the blade  $180^\circ$  and slide the table with the measuring device to position (B) in **Figure 85**.



**Figure 85.** Measuring gap between the table and the blade.

6. Measure the difference between the two positions (use the feeler gauge if using the adjustable square). Make note of the difference between the two measurements.

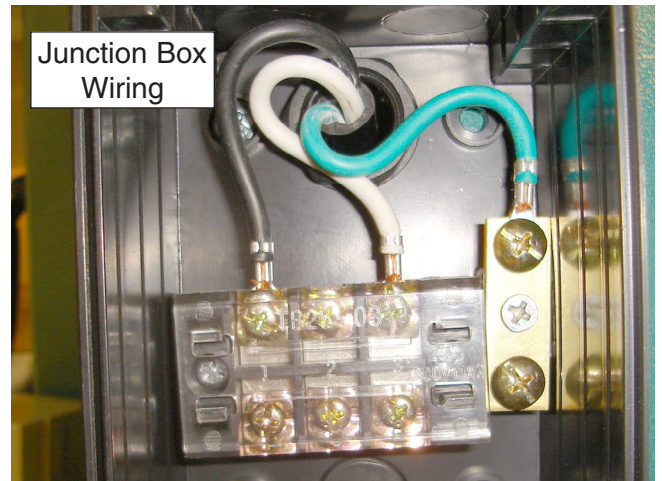
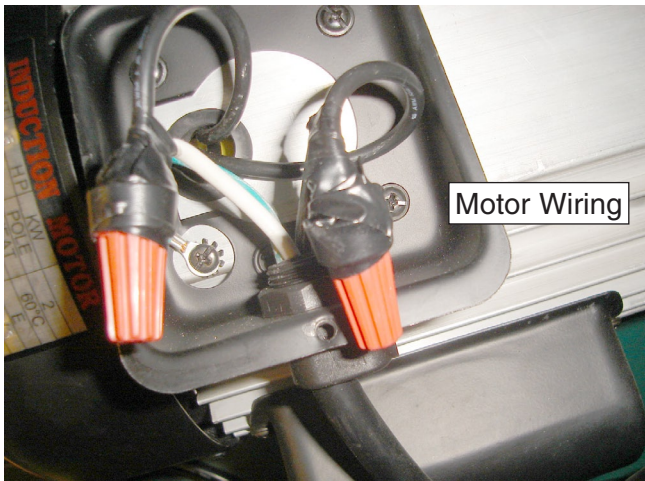
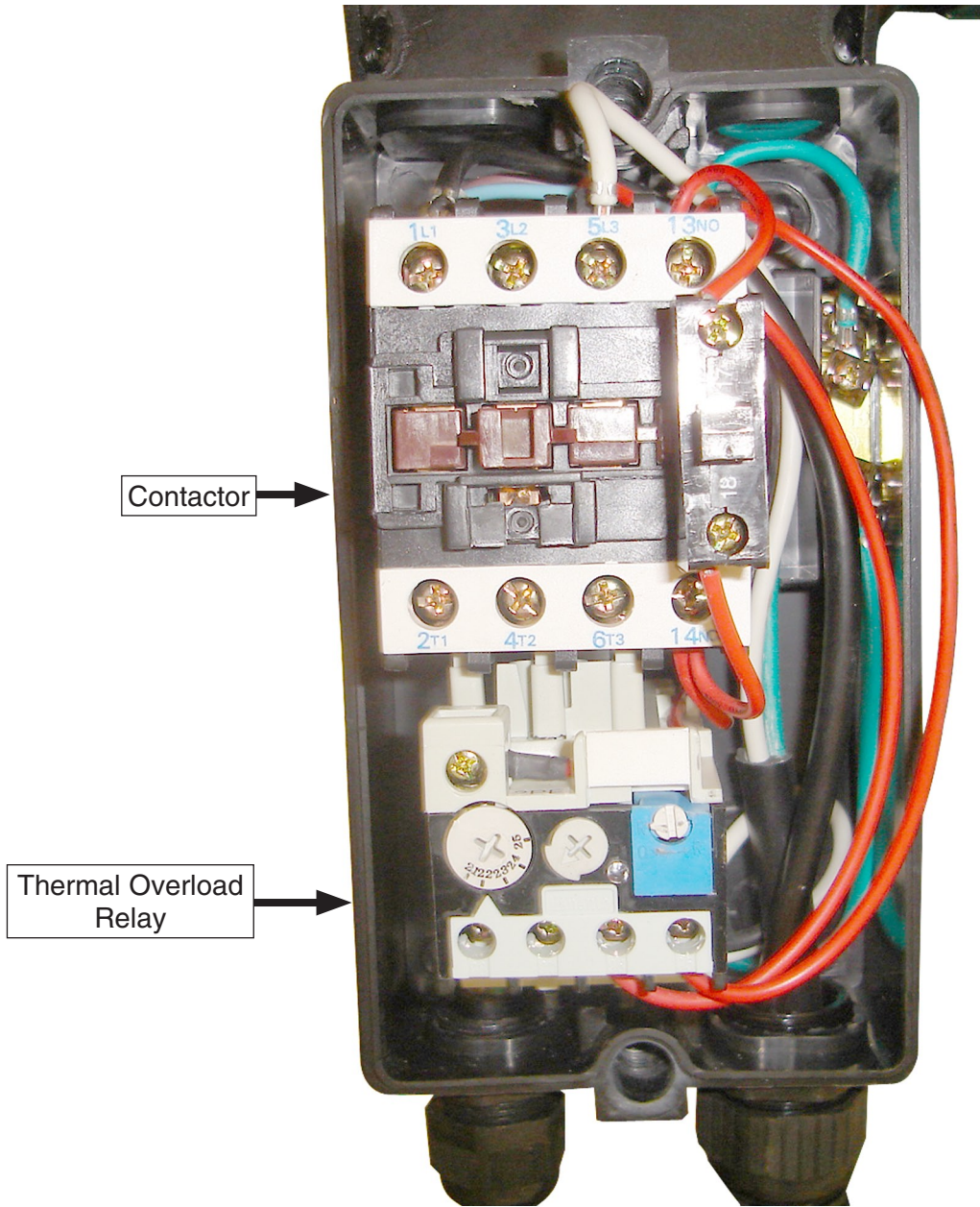
—If the difference is less than 0.004" then the blade parallelism is correct.

—If the difference is greater than 0.004", then the sliding table needs to be adjusted. Continue with the next step.

7. Push the end of the table that is closer to the blade out half the distance noted in **Step 6**.
8. Repeat **Steps 4-7** until the gap between the blade and the sliding table is equal.
9. Tighten the table mounting nuts to secure the sliding table and replace the access plates.

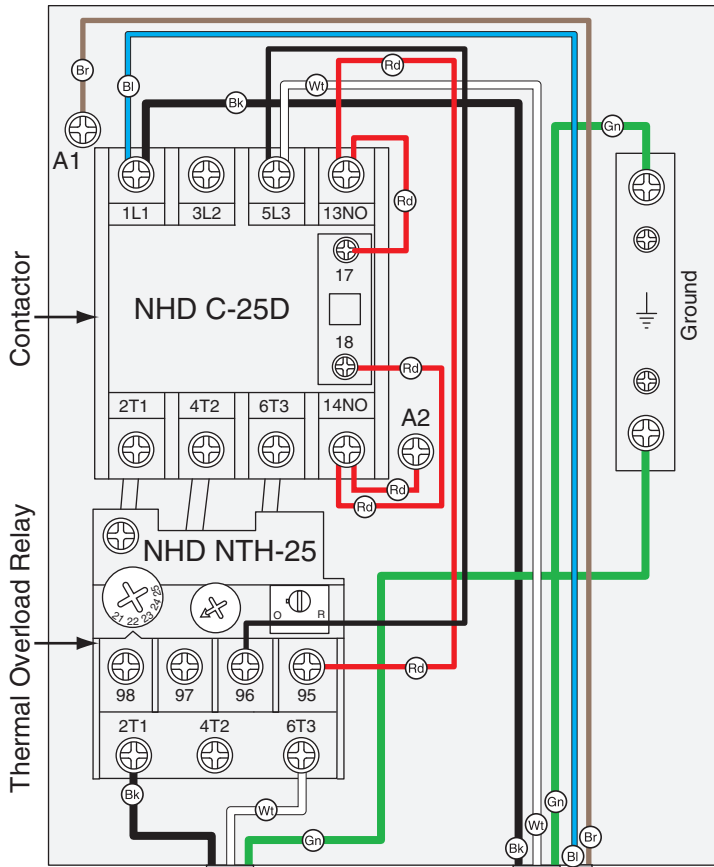


# G0460 Electrical Components



# G0460 Wiring Diagram

## MAGNETIC SWITCH ASSY

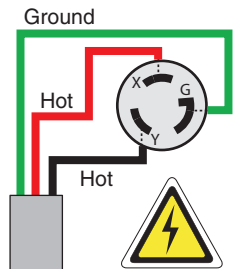


COLOR KEY	
BLACK	
WHITE	
GREEN	
RED	
BLUE	
BROWN	

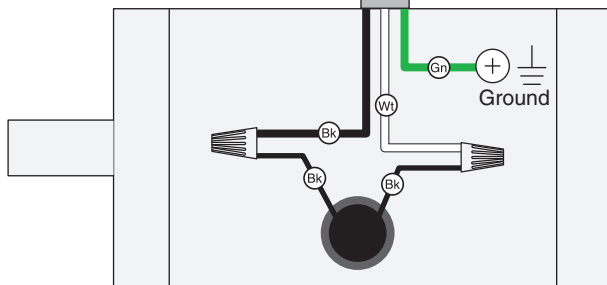
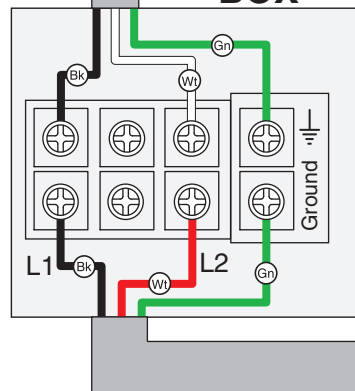
## LIMIT SWITCH



## L6-30 PLUG (as recommended)



## JUNCTION BOX



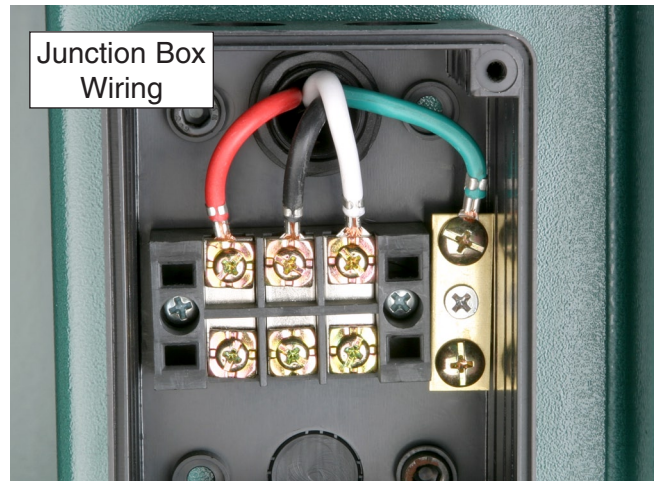
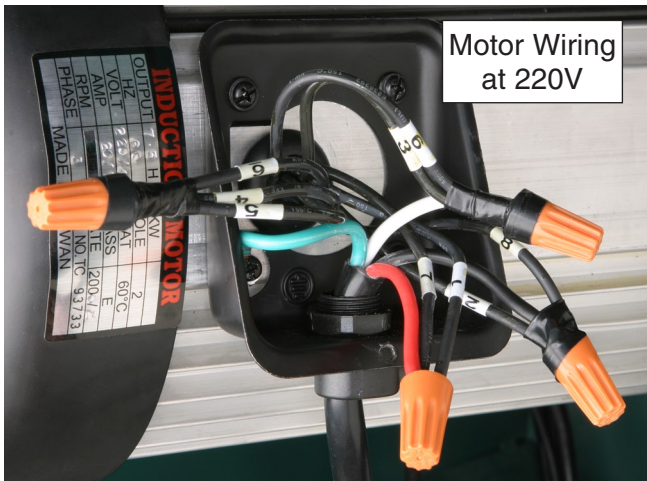
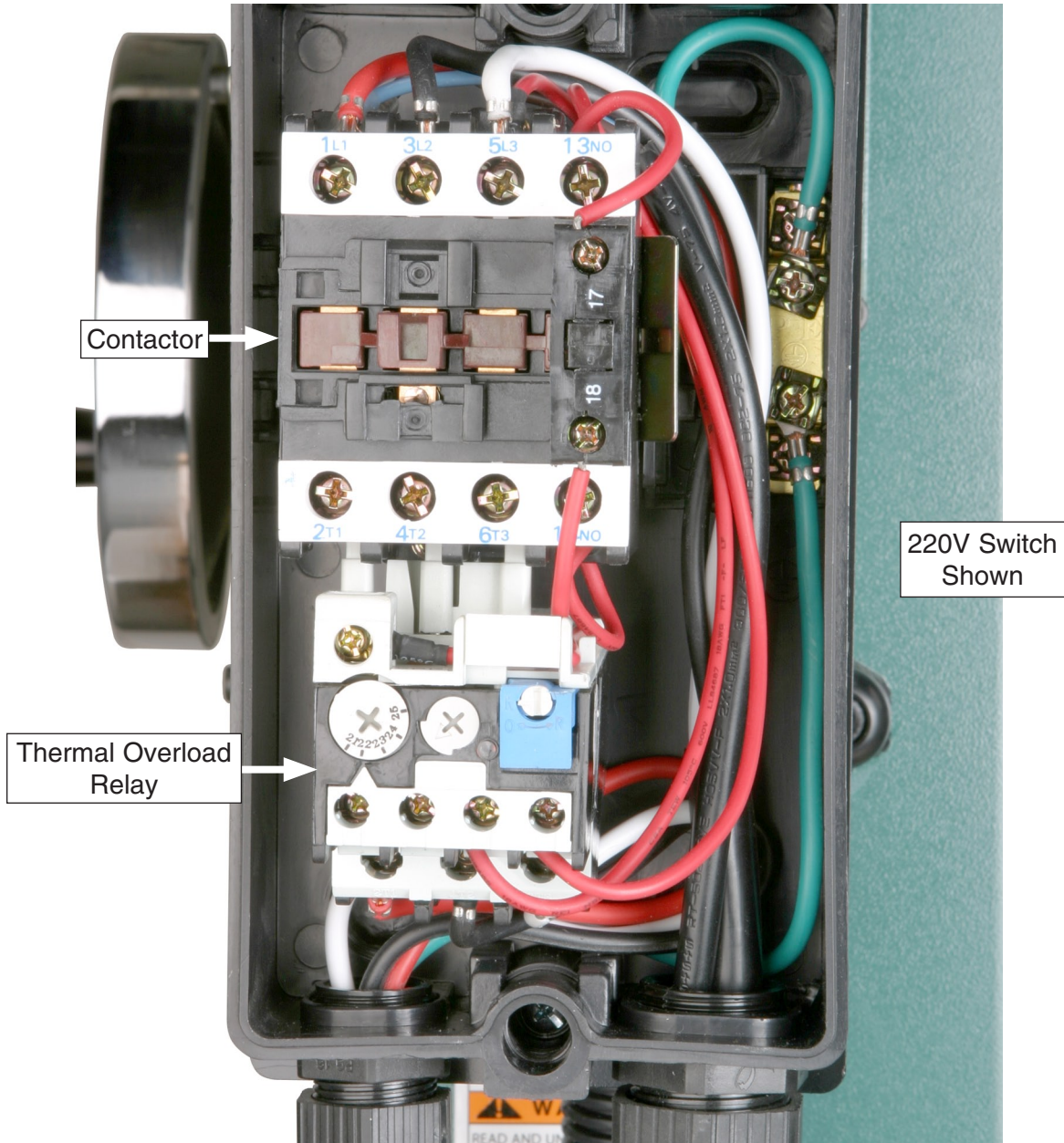
## MOTOR

### NOTICE

The motor wiring shown here is current at the time of printing; however, always use the diagram on the inside of junction box cover when rewiring your motor.

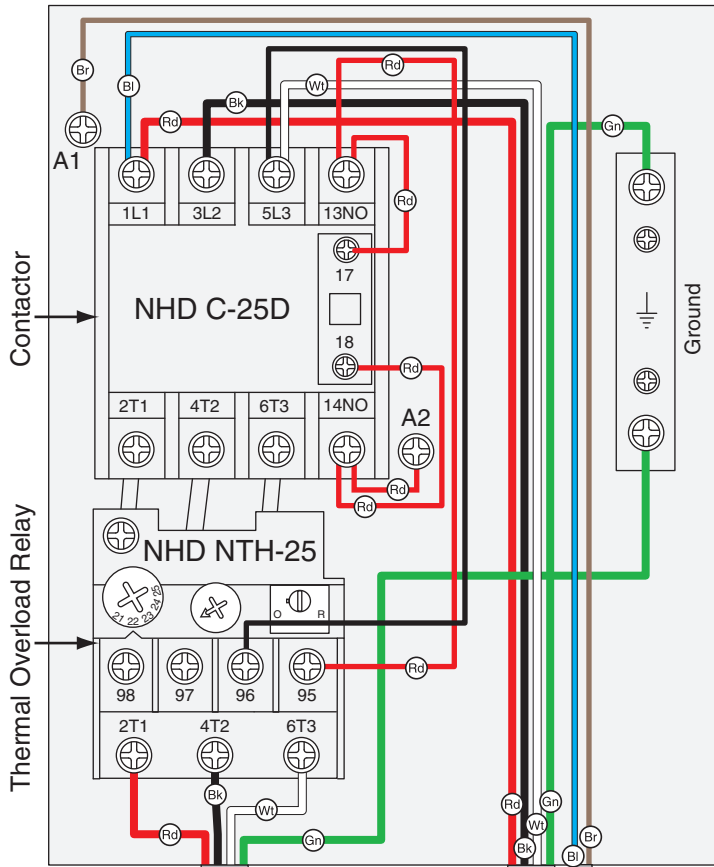


# G0461 Electrical Components



# G0461 Wiring Diagram at 220V

## MAGNETIC SWITCH ASSY



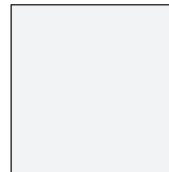
COLOR KEY	
BLACK	Bk
WHITE	Wr
GREEN	Gn
RED	Rd
BLUE	Bl
BROWN	Br

Contactor

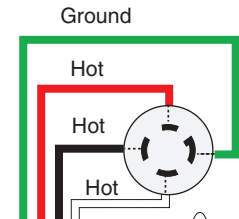
Thermal Overload Relay

Ground

## LIMIT SWITCH

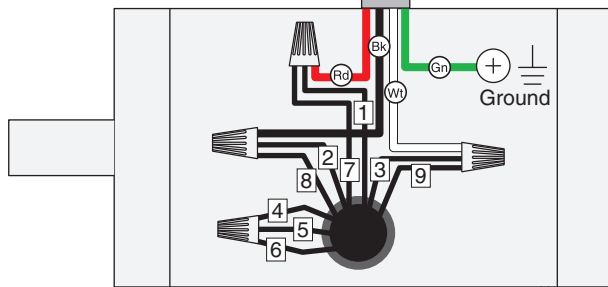
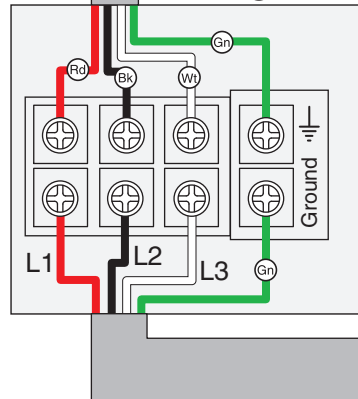


## L15-30 PLUG (as recommended)



220 VAC  
3-PHASE

## JUNCTION BOX



## MOTOR

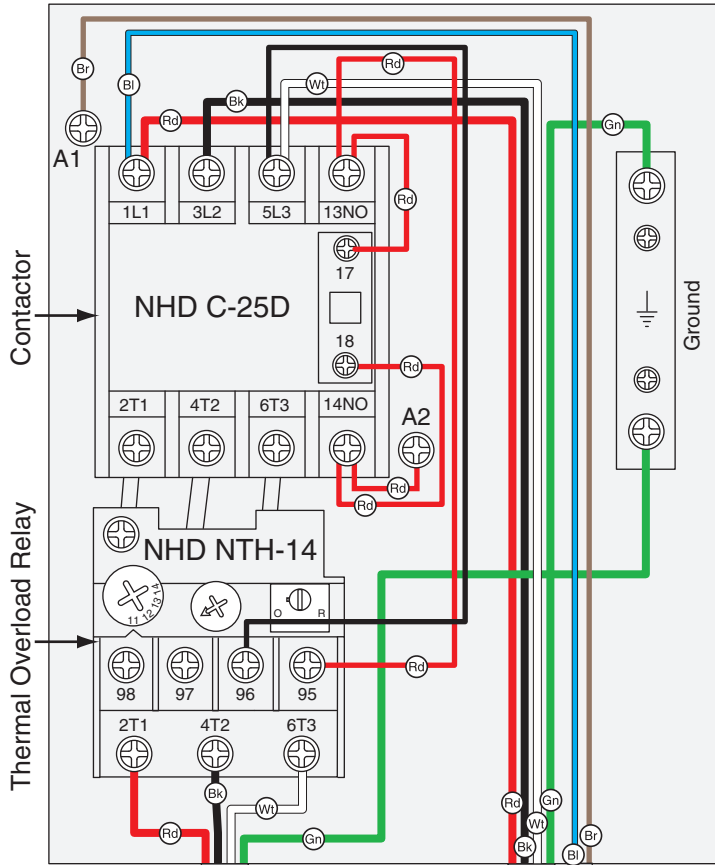
**NOTICE**  
The motor wiring shown here is current at the time of printing; however, always use the diagram on the inside of junction box cover when rewiring your motor.

**NOTICE**  
If motor rotates in the opposite direction, swap the black or red wires at the power source.



# G0461 Wiring Diagram at 440V

## MAGNETIC SWITCH ASSY



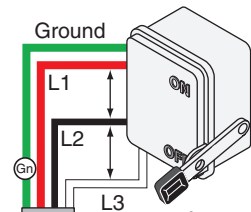
**⚠ WARNING!**  
**SHOCK HAZARD!**  
 Disconnect power before working on wiring.

COLOR KEY	
BLACK	
WHITE	
GREEN	
RED	
BLUE	
BROWN	

### LIMIT SWITCH

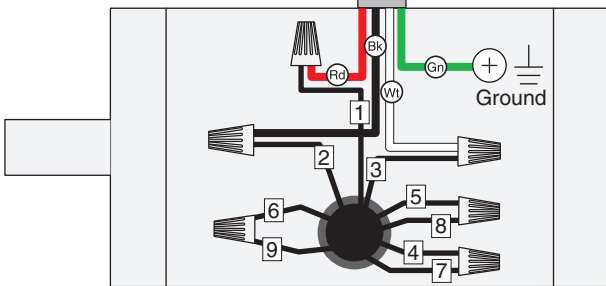
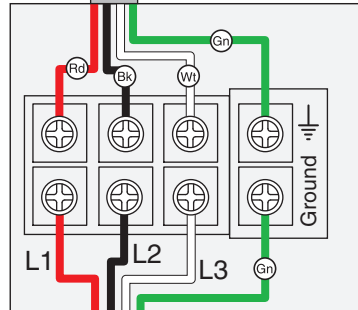


### DISCONNECT SWITCH (as recommended)



**3-PHASE  
440 VAC**

### JUNCTION BOX



### MOTOR

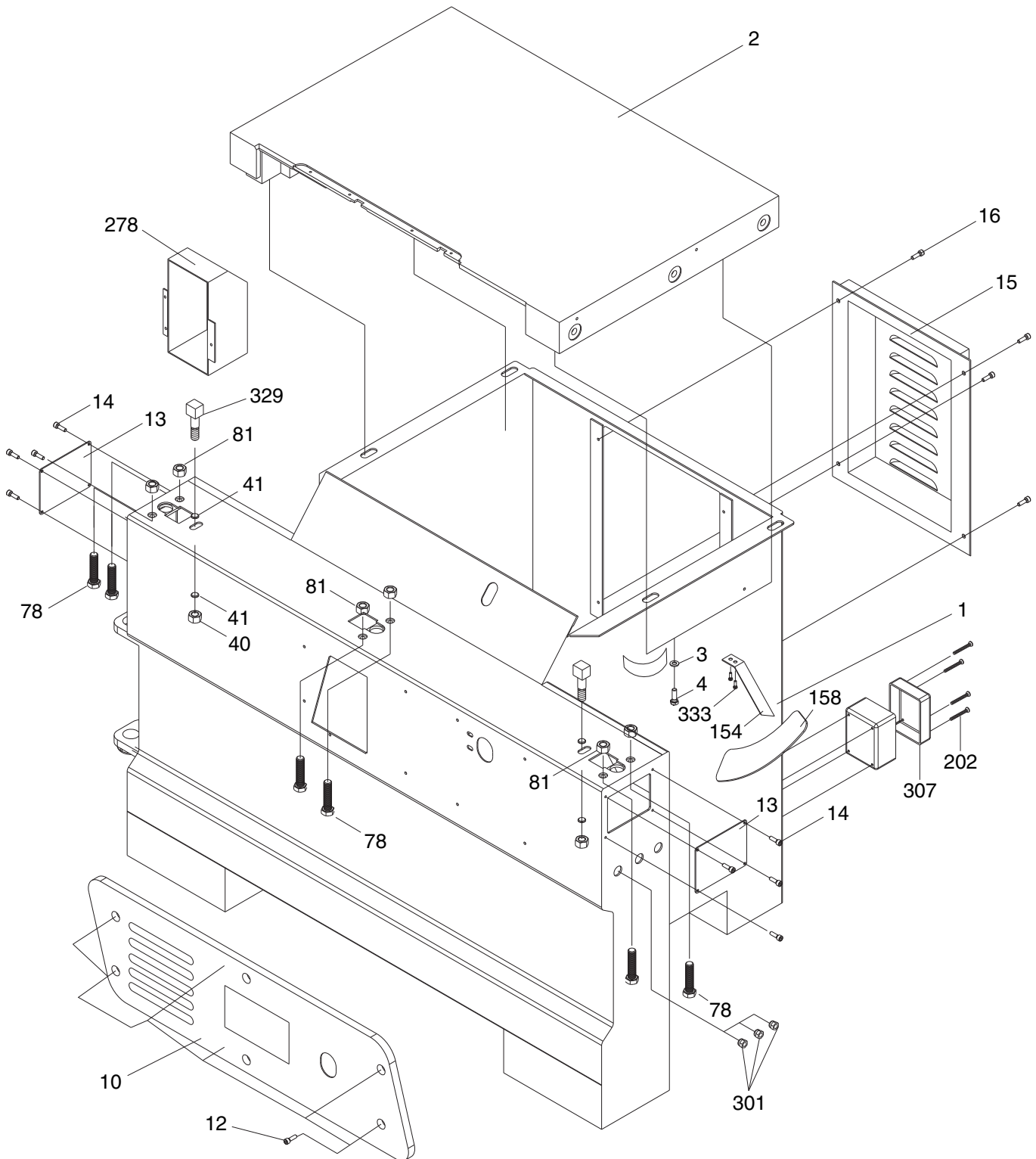
**NOTICE**  
 The motor wiring shown here is current at the time of printing; however, always use the diagram on the inside of junction box cover when rewiring your motor.

**NOTICE**  
 If motor rotates in the opposite direction, swap the black or red wires at the power source.



# SECTION 8: PARTS

## Main Body



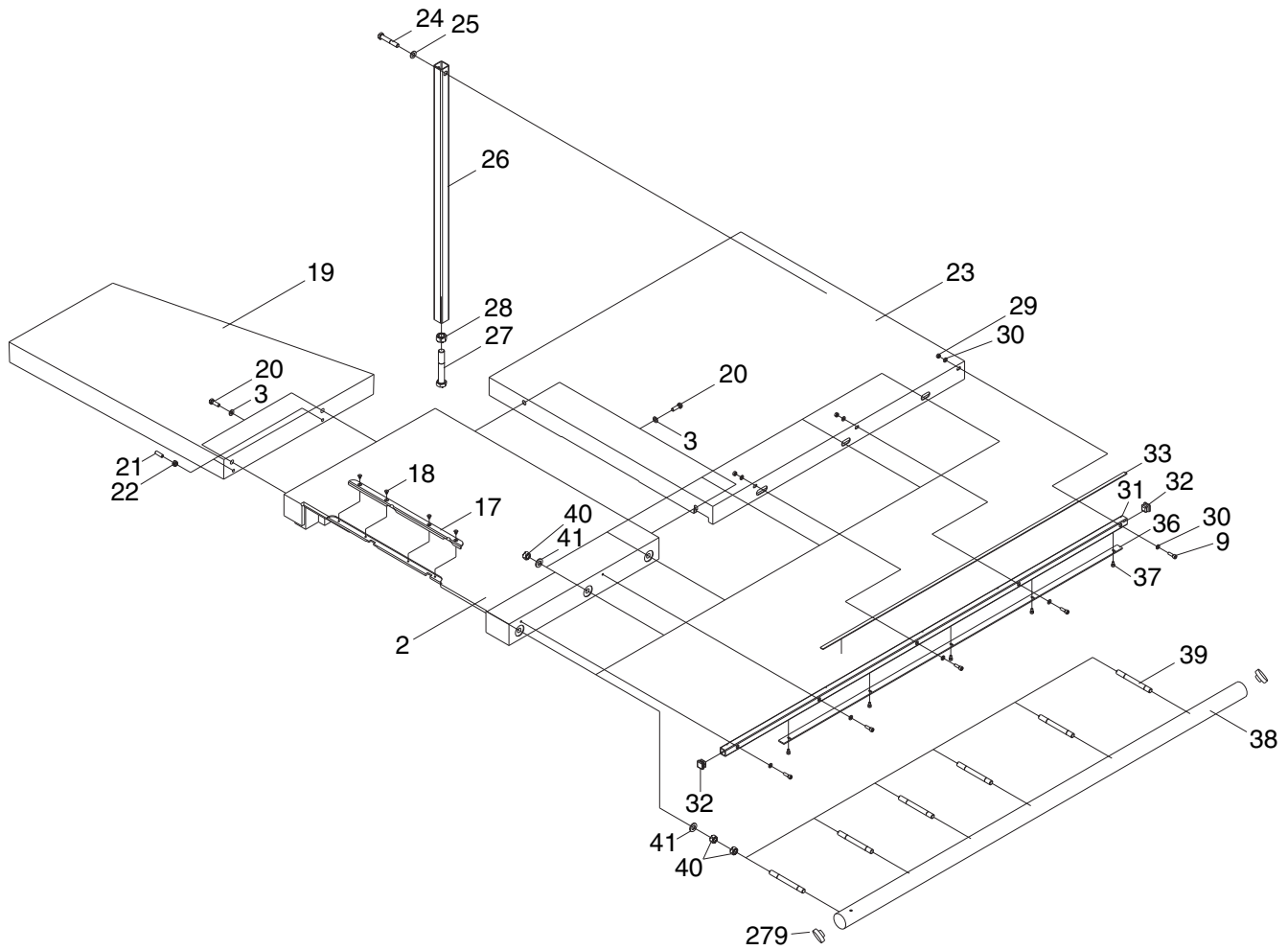


# Main Body Parts List

REF	PART #	DESCRIPTION
1	P0460001	BODY
2	P0588002	TABLE
3	PW01M	FLAT WASHER 8MM
4	PSB13M	CAP SCREW M8-1.25 X 30
10	P0460010	COVER PLATE
12	PSB02M	CAP SCREW M6-1 X 20
13	P0588013	ADJUSTMENT BOLT COVER
14	PSB26M	CAP SCREW M6-1 X 12
15	P0588015	MOTOR COVER
16	PSB49M	CAP SCREW M6-1 X 60
40	PN09M	HEX NUT M12-1.75
41	PW06M	FLAT WASHER 12MM
78	PB137M	HEX BOLT M14-2 X 30
81	PN32M	HEX NUT M14-2
154	P0460154	POINTER
158	P0460158	SCALE
202	P0588202	JUNCTION BOX SCREW
278	P0588278	SCALE DUST COVER
301	P0460301	STRAIN RELIEF
307	P0588307	JUNCTION BOX
329	P0460329	POSITION SCREW
333	P0460333	PHLP HD SCR M5-.8 X 8



# Extension Tables

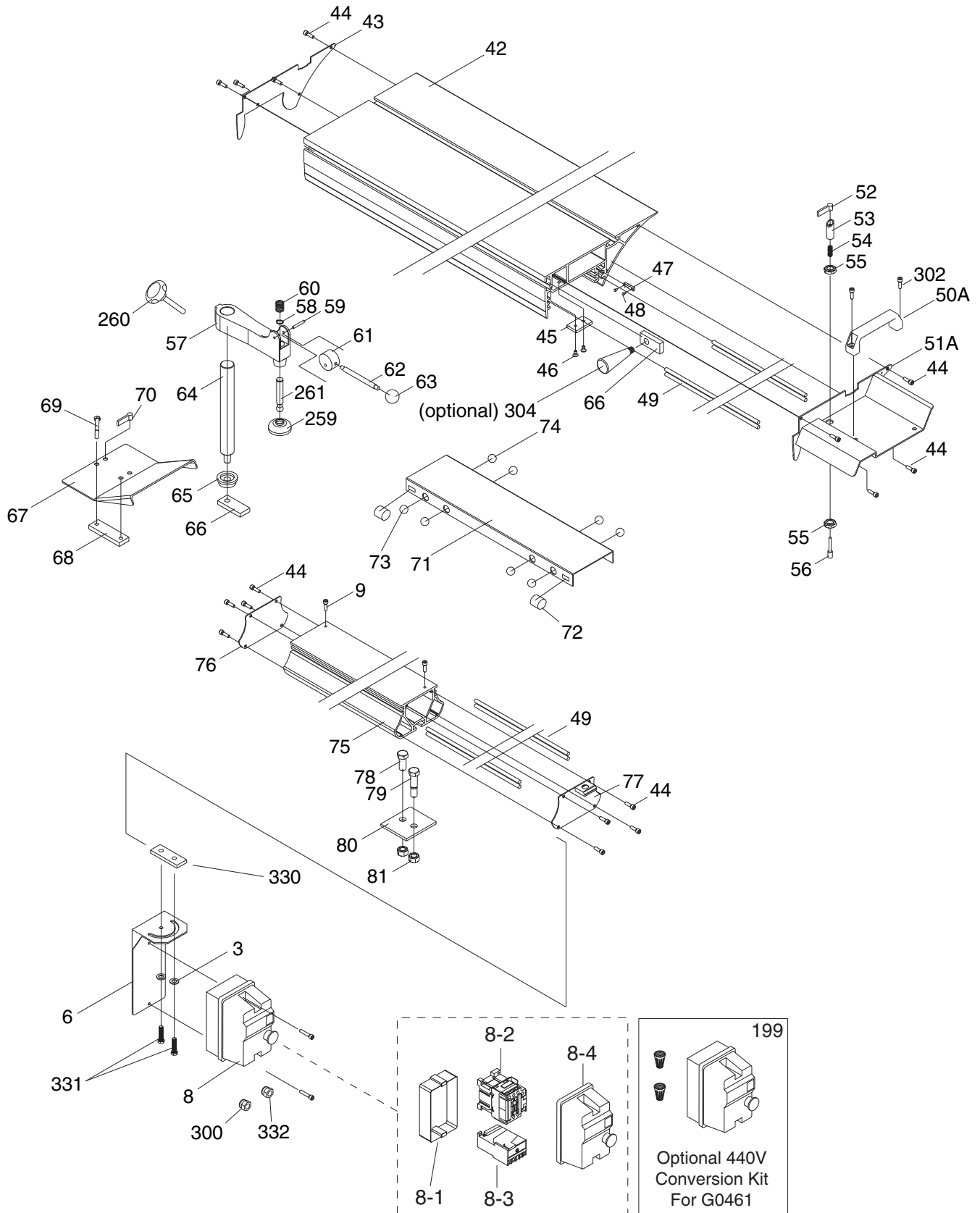


REF	PART #	DESCRIPTION
2	P0588002	TABLE
3	PW01M	FLAT WASHER 8MM
8	P0588008	MAG. SWITCH 220V-75HP (G0461)
17	P0588017	TABLE INSERT
18	PFH07M	FLAT HD SCR M5-.8 X 10
19	P0588019	EXTENSION WING (FRONT)
20	PSB13M	CAP SCREW M8-1.25 X 30
21	PSS16M	SET SCREW M8-1.25 X 10
22	PN03M	HEX NUT M8-1.25
23	P0588023	EXTENSION WING (RIGHT)
24	PB34M	HEX BOLT M10-1.5 X 60
25	PN02M	HEX NUT M10-1.5
26	P0588026	EXTENSION WING LEG
27	PB138M	HEX BOLT M16-2 X 100

REF	PART #	DESCRIPTION
28	PN13M	HEX NUT M16-2
29	PN01M	HEX NUT M6-1
30	PW03M	FLAT WASHER 6MM
31	P0588031	SCALE BAR
32	P0588032	SCALE BAR PLUG
33	P0588033	SCALE
36	P0588036	RACK
37	PSB03M	CAP SCREW M5-.8 X 8
38	P0588038	RAIL
39	P0588039	STUD M12-1.75 X 120
40	PN09M	HEX NUT M12-1.75
41	PW06M	FLAT WASHER 12MM
279	P0588279	FENCE RAIL PLUG 45 X 33



# Sliding Table



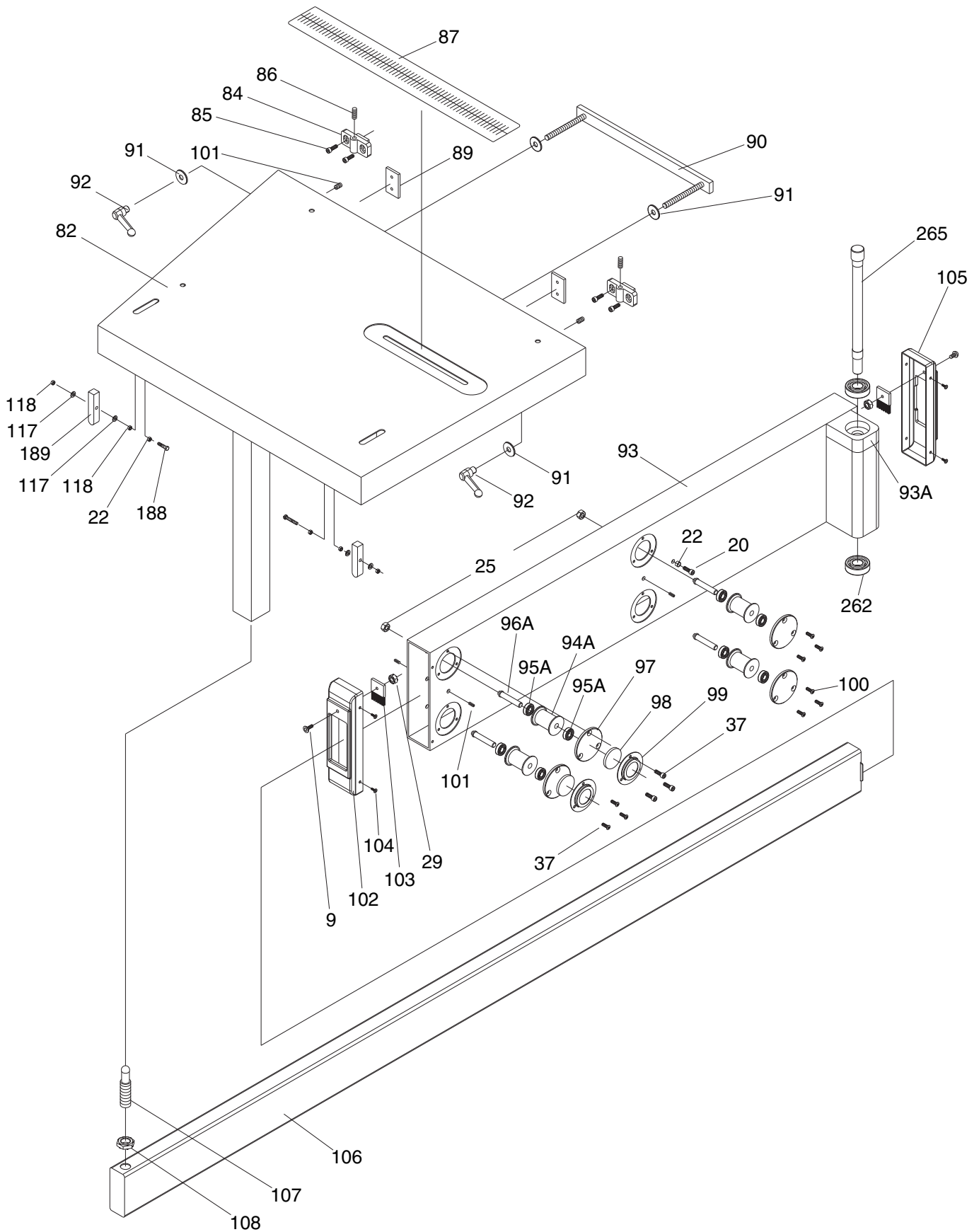
# Sliding Table Parts List

REF	PART #	DESCRIPTION
3	PW01M	FLAT WASHER 8MM
6	P0460006	SWITCH BASE
8	P0588008	MAG. SWITCH 220V-7.5HP 3Ø & 5HP 1Ø
8-1	P0588008-1	MAG. SWITCH REAR COVER
8-2	P0588008-2	CONTACTOR 220V
8-3	P0588008-3	OVERLOAD RELAY 21-25A
8-4	P0588008-4	MAG SWITCH FRONT COVER
9	PSB01M	CAP SCREW M6-1 X 16
42	P0460042	SLIDING TABLE
43	P0588043	SLIDING TABLE END COVER
44	PSB01M	CAP SCREW M6-1 X 16
45	P0588045	RUBBER PLATE
46	PFH23M	FLAT HD SCR M8-1.25 X 16
47	P0588047	GIB
48	PB83M	HEX BOLT M6-1 X 16
49	P0588049	STEEL RAILS
50A	P0588050	HANDLE
51A	P0588051	HANDLE COVER
52	P0588052	STOP LEVER
53	P0588053	SLEEVE
54	P0588054	EXTENSION SPRING
55	PN13M	HEX NUT M16-2
56	P0588056	STOP PIN
57	P0588057	HOLD DOWN BRACKET
58	PR02M	EXT. RETAINING RING 14MM
59	PRP45M	ROLL PIN 5 X 32
60	P0588060	COMPRESSION SPRING
61	P0588061	CAM
62	P0588062	HANDLE SHAFT

REF	PART #	DESCRIPTION
63	P0588063	BALL KNOB
64	P0588064	HOLD DOWN ARBOR
65	P0588065	PLASTIC HOLD DOWN WASHER
66	P0588066	T-NUT PLATE
67	P0588067	EDGE SHOE PLATE
68	P0588068	T-NUT PLATE
69	PB74M	HEX BOLT M10-1.5 X 20
70	P0588070	ADJUSTABLE HANDLE M10-1.5 X 16
71	P0460071	SLED
72	P0588072	SLED SPONGE
73	P0588073	STEEL BALL 18MM
74	P0588074	STEEL BALL 11/16MM
75	P0460075	SLIDING TABLE RAIL
76	P0588076	TABLE RAIL COVER (BACK)
77	P0588077	TABLE RAIL COVER (FRONT)
78	PB137M	HEX BOLT M14-2 X 30
79	PB153M	HEX BOLT M14-2 X 40
80	P0588080	ADJUSTMENT PLATE
81	PN32M	HEX NUT M14-2
199	P0588199	440V CONVERSION KIT (G0461)
259	P0588259	HOLD DOWN PLATE
260	P0588260	KNOB M8-1.25 X 20
261	P0588261	HOLD DOWN SHAFT
300	P0460300	STRAIN RELIEF PG1335
302	PSB14M	CAP SCREW M8-1.25 X 20
304	P0588304	PUSH HANDLE M14-2 X 16 (OPTIONAL)
330	P0460330	SWITCH BASE FIX PLATE
331	P0460331	HEX BOLT M8-1.25 X 20
332	P0460332	STRAIN RELIEF



# Crosscut Table

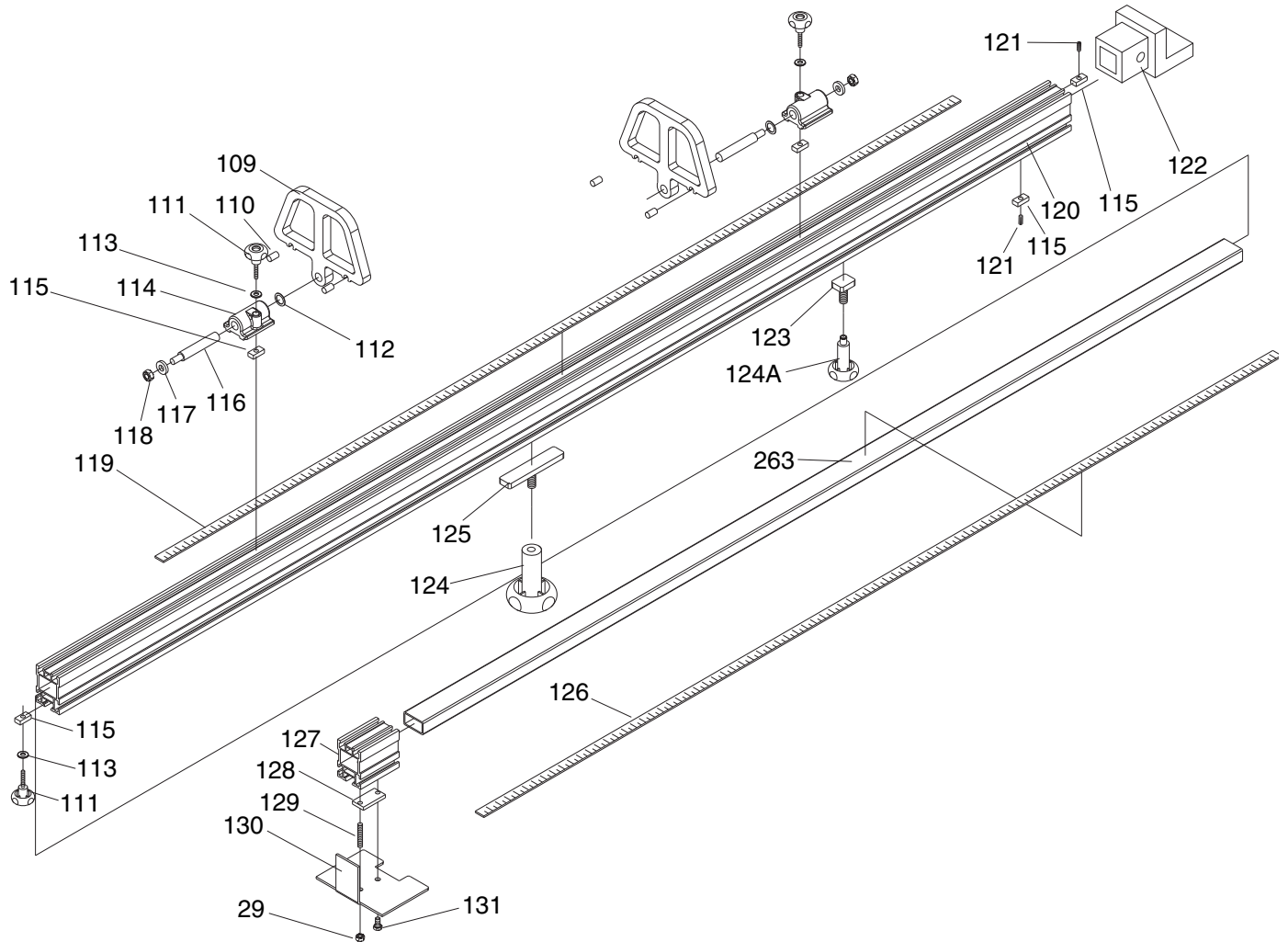


# Crosscut Table Parts List

REF	PART #	DESCRIPTION
9	PSB01M	CAP SCREW M6-1 X 16
20	PSB13M	CAP SCREW M8-1.25 X 30
22	PN03M	HEX NUT M8-1.25
25	PN02M	HEX NUT M10-1.5
29	PN01M	HEX NUT M6-1
37	PSB03M	CAP SCREW M5-.8 X 8
82	P0460082	CROSSCUT TABLE
84	P0588084	SUPPORT ADJUSTMENT BLOCK
85	PSB04M	CAP SCREW M6-1 X 10
86	PSS09M	SET SCREW M8-1.25 X 20
87	P0460087	SCALE LABEL (RIGHT)
89	P0588089	SLIDING SURFACE PLATE
90	P0588090	CROSSCUT TABLE LOCK PLATE
91	PW04M	FLAT WASHER 10MM
92	P0588092	ADJUST HANDLE M10-1.5
93	P0460093	SWING ARM
93A	P0460093A	SWING ARM ATTACHMENT
94A	P0588094A	ECCENTRIC ROLLER
95A	P6901	BALL BEARING 6901
96A	P0588096A	ECCENTRIC SHAFT
97	P0588097	ROTATE ARBOR SUPPORT
98	P0588098	MAGNET
99	P0588099	MAGNET BASE
100	PFH30M	FLAT HD SCR M5-.8 X 8
101	P0588101	NYLON SCREW M12-1.75 X 12
102	P0588102	SWING ARM END
103	P0588103	BRUSH
104	PSB117M	BUTTON HD CAP SCR M5-.8 X 8
105	P0588105	SWING ARM END
106	P0460106	EXTENSION SWING ARM
107	P0588107	SWING ARM ADJUST SCREW M20-2.5
108	PN28M	HEX NUT M20-2.5
117	PW01M	FLAT WASHER 8MM
118	PLN04M	LOCK NUT M8-1.25
188	P0460188	HEX BOLT M8-1.25 X 100
189	P0588189	STOP BLOCK
262	P6204	BALL BEARING 6204ZZ
265	P0588265	SWING ARM SHAFT



# Crosscut Fence

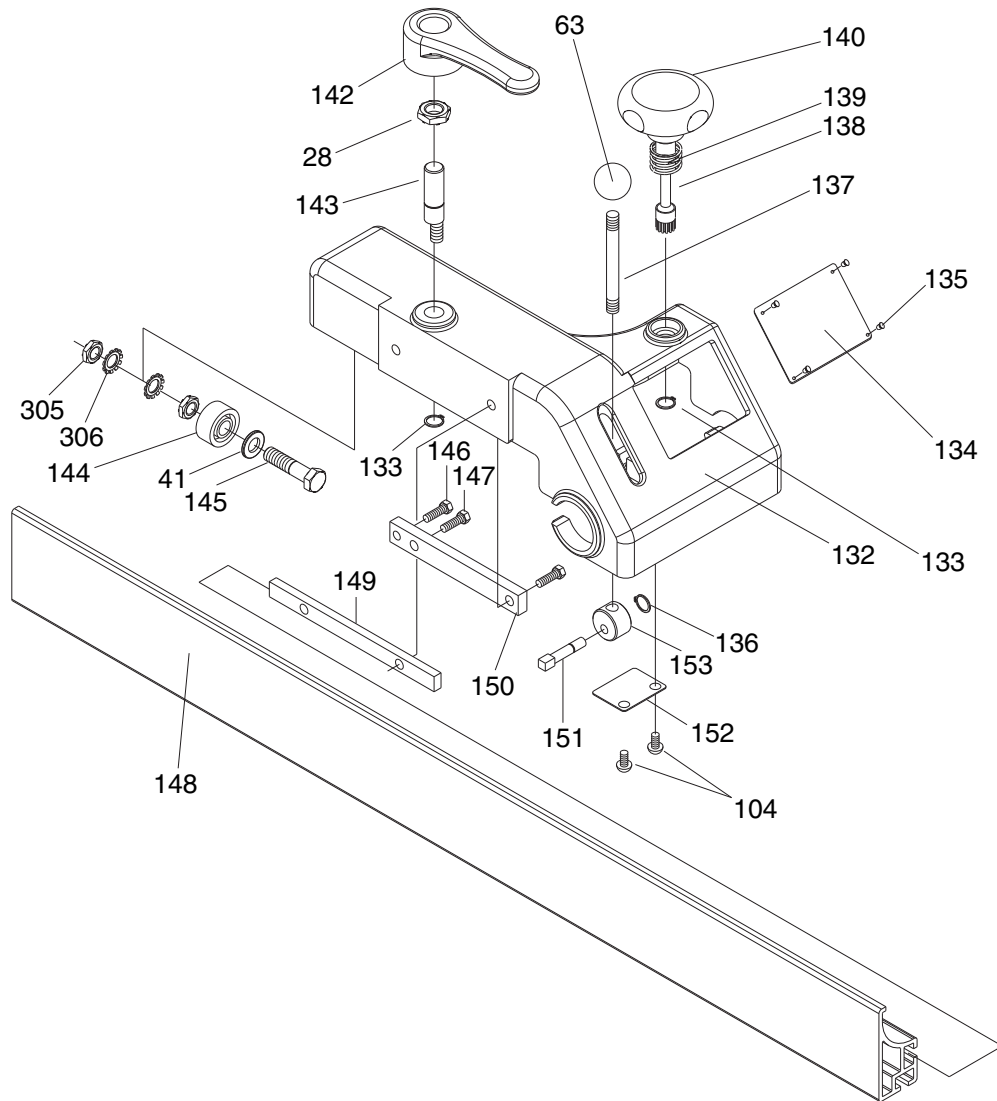


REF	PART #	DESCRIPTION
29	PN01M	HEX NUT M6-1
109	P0588109	STOP PLATE
110	P0588110	NYLON PAD
111	P0588111	KNOB M6-1 X 35
112	PW01M	FLAT WASHER 8MM
113	PW03M	FLAT WASHER 6MM
114	P0588114	CLAMPING BASE
115	P0588115	T-NUT M6-1
116	P0588116	CLAMPING ARBOR
117	PW01M	FLAT WASHER 8MM
118	PLN04M	LOCK NUT M8-1.25
119	P0460119	SCALE (LONG)
120	P0460120	CROSSCUT FENCE

REF	PART #	DESCRIPTION
121	PSS04M	SET SCREW M6-1 X 12
122	P0588122	PROTECTION BLOCK
123	P0588123	T-BOLT M10-1.5
124	P0588124	KNOB M10-1.5
124A	P0460124A	KNOB W/SHOULDER
125	P0588125	LOCK PLATE M10-1.5 X 25
126	P0460126	SCALE(SHORT)
127	P0588127	CROSS CUTTING FENCE-SHORT BASE
128	P0588128	LOCK PLATE
129	PSS29M	SET SCREW M6-1 X 35
130	P0588130	CROSS FENCE SUPPORT PLATE
131	PS31M	PHLP HD SCR M6-1 X 35
263	P0460263	SCALE TUBE



# Rip Fence



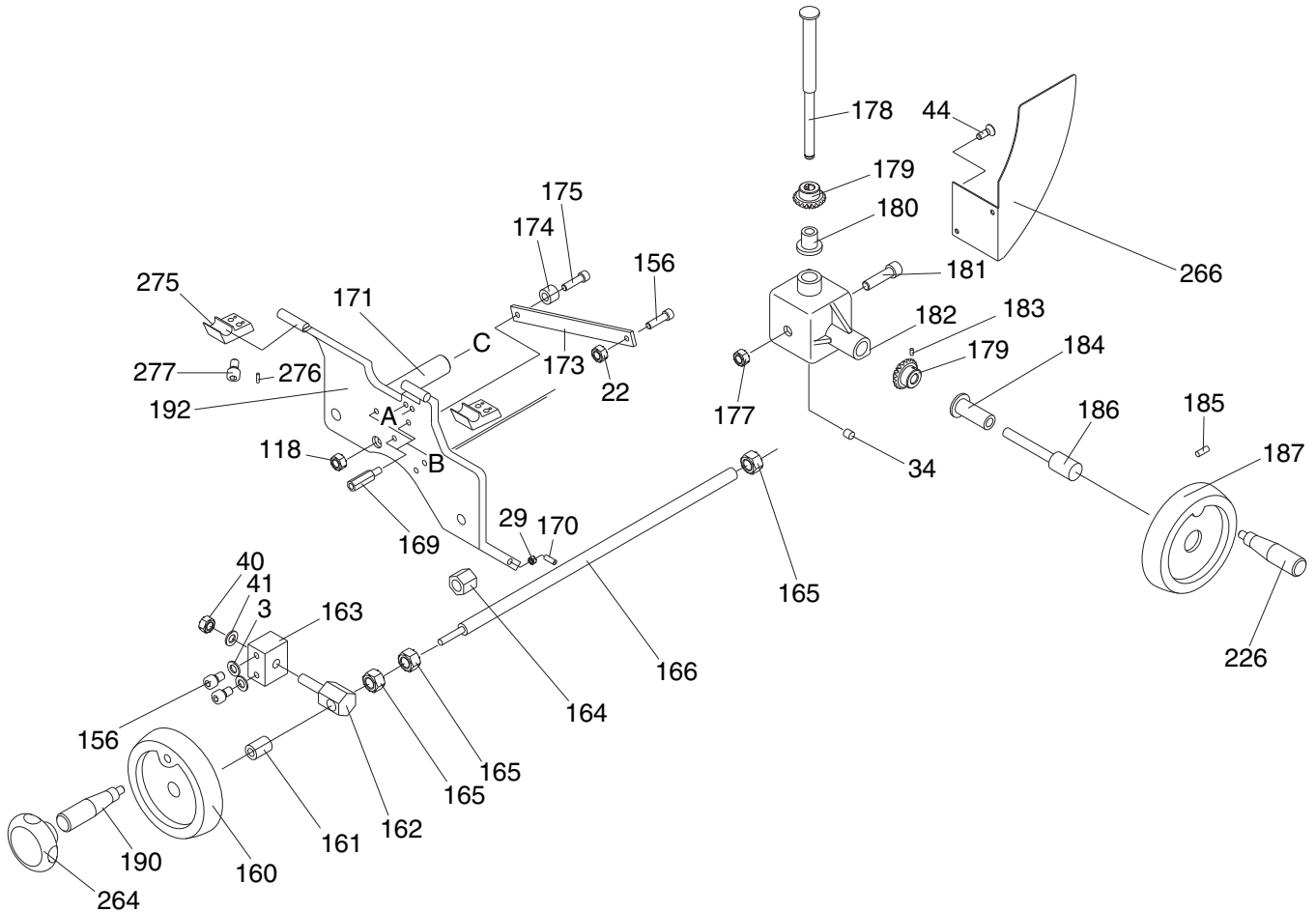
REF	PART #	DESCRIPTION
41	PW06M	FLAT WASHER 12MM
28	PN13M	HEX NUT M16-2
63	P0588063	BALL KNOB
104	PSB117M	BUTTON HD CAP SCR M5-.8 X 8
132	P0588132	RIP FENCE BASE
133	PR06M	EXT RETAINING RING 16MM
134	P0588134	WARNING LABEL PLATE
135	P0588135	RIVET
136	PR36M	EXT RETAINING RING 7MM
137	P0588137	KNOB SHAFT
138	P0460138	KNOB SHAFT W/GEAR
139	P0588139	COMPRESSION SPRING
140	P0588140	KNOB M14-1.75
142	P0588142	FENCE CLAMP HANDLE

REF	PART #	DESCRIPTION
143	P0588143	ECCENTRIC SHAFT
144	P0588144	ROLLER
145	PB33M	HEX BOLT M12-1.75 X 50
146	PSB14M	HEX BOLT M8-1.25 X 20
147	PB28M	HEX BOLT M8-1.25 X 60
148	P0588148	RIP FENCE PLATE
149	P0588149	LOCK BLOCK (LONG)
150	P0588150	LOCK BLOCK (SHORT)
151	P0588151	ECCENTRIC SHAFT
152	P0588152	HOLD PLATE
153	P0588153A	ECCENTRIC
305	PN09M	HEX NUT M12-1.75
306	PTLW12M	EXT TOOTH WASHER 12MM





# Tilt Assembly

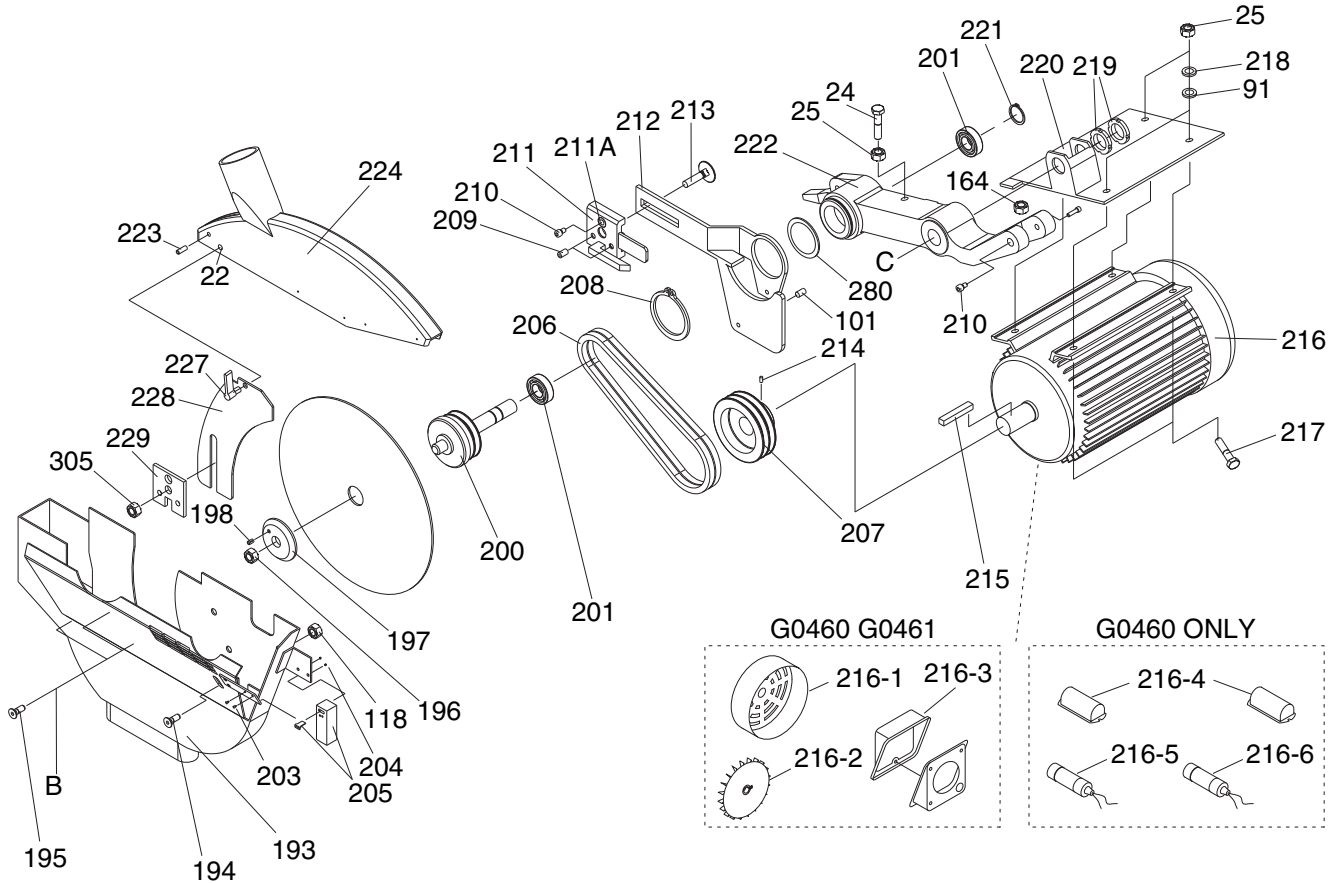


REF	PART #	DESCRIPTION
3	PW01M	FLAT WASHER 8MM
13	P0588013	ADJUSTMENT BOLT COVER
22	PN03M	HEX NUT M8-1.25
29	PN01M	HEX NUT M6-1
40	PN09M	HEX NUT M12-1.75
41	PW06M	FLAT WASHER 12MM
44	PSB01M	CAP SCREW M6-1 X 16
118	PLN04M	LOCK NUT M8-1.25
156	PSB40M	CAP SCREW M8-1.25 X 35
160	P0588160	HAND WHEEL
161	P0588161	HAND WHEEL COLLAR
162	P0588162	SHAFT NUT
163	P0588163	SHAFT NUT BASE
164	P0588164	TW-NUT
165	P0588165	LEAD SCREW NUT
166	P0588166	LEAD SCREW TW-16 8 TEETH/ INCH
169	P0588169	COVER SUPPORT M6-1 X 25
170	P0588170	SET SHAFT
171	P0588171	BODY ARBOR
173	P0588173	CRANK ARM
174	P0588174	PULLEY COLLAR

REF	PART #	DESCRIPTION
175	PSB40M	CAP SCREW M8-1.25 X 35
177	PLN07M	LOCK NUT 16-2
178	P0588178	WORM
179	P0588179	WORM GEAR
180	P0588180	COPPER SLEEVE
181	PSB54M	CAP SCREW M16-2 X 40
182	P0588182	GEAR BOX
183	PSS11	SET SCREW 1/4-20 X 1/4
184	P0588184	COPPER SLEEVE
185	PSS59M	SET SCREW M8-1.25 X 14
186	P0588186	HAND WHEEL SHAFT
187	P0588187	HAND WHEEL
190	P0588190	FOLDABLE HANDLE HL-80
192	P0588192	ARBOR PLATE
226	P0460226	HANDWHEEL HANDLE
264	P0588264	KNOB M10-1.5
266	P0588266	COVER (UPPER)
275	P0588275	ROTATE PART LOCK
276	PRP42M	ROLL PIN 3 X 20
277	PSB14M	CAP SCREW M8-1.25 X 20



# Motor Assembly

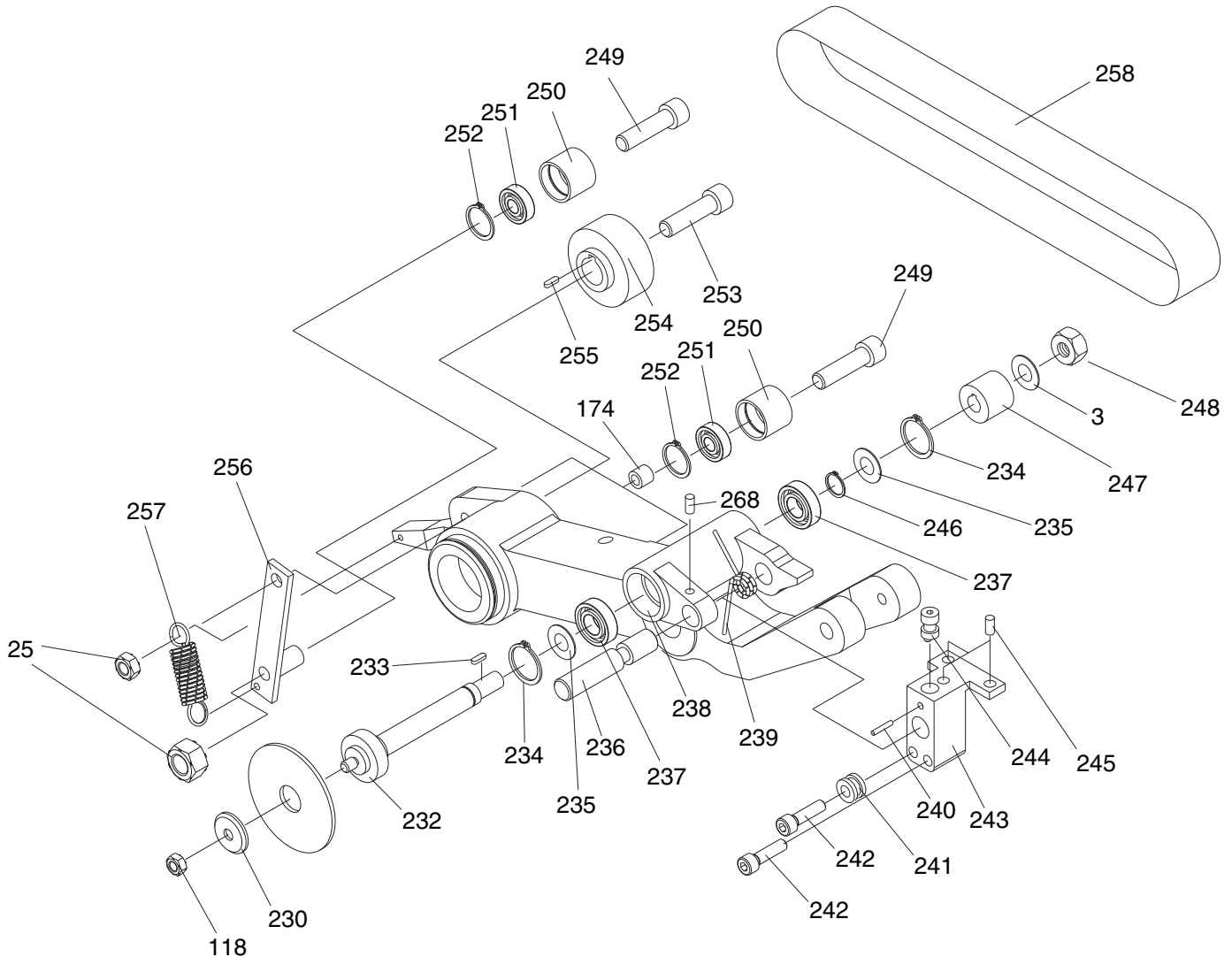


REF	PART #	DESCRIPTION
24	PB34M	HEX BOLT M10-1.5 X 60
25	PN02M	HEX NUT M10-1.5
91	PW04M	FLAT WASHER 10MM
101	P0588101	NYLON SCREW M12-1.75 X 12
118	PLN04M	LOCK NUT M8-1.25
164	P0588164	TW-NUT
193	P0588193	DUST COVER
194	PFH23M	FLAT HD SCR M8-1.25 X 16
195	PFH11M	FLAT HD SCR M8-1.25 X 15
196	P0588196	HEX NUT M16-2 (LH)
197	P0588197	ARBOR FLANGE
198	PRP74M	ROLL PIN 4 X 8
200	P0588200	BLADE ARBOR
201	P6004	BALL BEARING 6004ZZ
203	PSB46M	CAP SCREW M4-.7 X 40
204	PN04M	HEX NUT M4-.7
205	P0588205	LIMIT SWITCH
206	P0588206	COGGED V-BELT MX-26.5
207	P0588207	MOTOR PULLEY
208	PR71M	EXT RETAINING RING 60MM
209	PSS16M	SET SCREW M8-1.25 X 10
210	PSB11M	CAP SCREW M8-1.25 X 16
211	P0588211	RIVING KNIFE HOLDER
211A	P0460211A	MAGNET
212	P0588212	RIVING BRACKET
213	PCB25M	CARRIAGE BOLT M12-1.75 X 35

REF	PART #	DESCRIPTION
214	PSS01M	SET SCREW M6-1 X 10
215	PK42M	KEY 6 X 6 X 30
216	P0591216	MOTOR 5HP-1PH (G0460)
216	P0588216	MOTOR 7.5HP-3PH (G0461)
216-1	P0588216-2	MOTOR FAN COVER (G0460)
216-1	P0591216-2	MOTOR FAN COVER (G0461)
216-2	P0588216-1	MOTOR FAN (G0460)
216-2	P0591216-1	MOTOR FAN (G0461)
216-3	P0588216-7	WIRING CONNECT BOX (G0460)
216-3	P0591216-7	WIRING CONNECT BOX (G0461)
216-4	P0460216-4	CAPACITOR COVER (G0460)
216-5	PC600	S CAPACITOR 600M 125V (G0460)
216-6	PC045A	R CAPACITOR 45M 250 V (G0460)
217	PB74M	HEX BOLT M10-1.5 X 20
218	PLW06M	LOCK WASHER 10MM
219	P0588219	SPANNER NUT M25-1.5
220	P0588220	MOTOR PLATE
221	PR09M	EXT RETAINING RING 20MM
222	P0588222	ROTATE HOUSING
223	PRP08M	ROLL PIN 6 X 30
224	P0588224	BLADE GUARD
227	P0588227	ADJUST HANDLE M8-1.25 X 30
228	P0588228	RIVING KNIFE
229	P0588229	COVER LOCK BLOCK
280	P0588280	WAVE WASHER 60MM
305	PN09M	HEX NUT M12-1.75



# Arbor Assembly



REF	PART #	DESCRIPTION
3	PW01M	FLAT WASHER 8MM
25	PN02M	HEX NUT M10-1.5
118	PLN04M	LOCK NUT M8-1.25
174	P0588174	PULLEY COLLAR
230	P0588230	SCORING BLADE WASHER
232	P0588232	SCORING ARBOR
233	PK47M	KEY 4 X 4 X 15
234	PR29M	INT RETAINING RING 32MM
235	P0588235	WAVE WASHER 15MM
236	P0588236	BLADE LINK SHAFT
237	P6002	BALL BEARING 6002ZZ
238	P0588238	BLADE LINK SHAFT
239	P0588239	TORSION SPRING
240	PSS02M	SET SCREW M6-1 X 6
241	P0588241	SLEEVE
242	PSB12M	CAP SCREW M8-1.25 X 40
243	P0588243	LINK SHAFT BASE

REF	PART #	DESCRIPTION
244	P0588244	ECCENTRIC SHAFT
245	P0460245	SET SCREW
246	PR05M	EXT RETAINING RING 15MM
247	P0588247	SCORING PULLEY
248	P0588248	HEX NUT M8-1.25 (LH)
249	PSB72M	CAP SCREW M10-1.5 X 30
250	P0588250	IDLE WHEEL
251	P6000	BALL BEARING 6000ZZ
252	PR40M	INT RETAINING RING 26MM
253	PSB130M	CAP SCREW M10-1.5 X 16
254	P0588254	FLAT BELT PULLEY
255	PK99M	KEY 6 X 6 X 15
256	P0588256	PULLEY SUPPORT
257	P0588257	EXTENSION SPRING
258	P0588258	FLAT BELT 17 X 930 X 1
268	PSS05M	SET SCREW M5-.8 X 10



# WARRANTY AND RETURNS

---

Grizzly Industrial, Inc. warrants every product it sells for a period of **1 year** to the original purchaser from the date of purchase. This warranty does not apply to defects due directly or indirectly to misuse, abuse, negligence, accidents, repairs or alterations or lack of maintenance. This is Grizzly's sole written warranty and any and all warranties that may be implied by law, including any merchantability or fitness, for any particular purpose, are hereby limited to the duration of this written warranty. We do not warrant or represent that the merchandise complies with the provisions of any law or acts unless the manufacturer so warrants. In no event shall Grizzly's liability under this warranty exceed the purchase price paid for the product and any legal actions brought against Grizzly shall be tried in the State of Washington, County of Whatcom.

We shall in no event be liable for death, injuries to persons or property or for incidental, contingent, special, or consequential damages arising from the use of our products.

To take advantage of this warranty, contact us by mail or phone and give us all the details. We will then issue you a "Return Number," which must be clearly posted on the outside as well as the inside of the carton. We will not accept any item back without this number. Proof of purchase must accompany the merchandise.

The manufacturers reserve the right to change specifications at any time because they constantly strive to achieve better quality equipment. We make every effort to ensure that our products meet high quality and durability standards and we hope you never need to use this warranty.

Please feel free to write or call us if you have any questions about the machine or the manual.

Thank you again for your business and continued support. We hope to serve you again soon.





# WARRANTY CARD

Name \_\_\_\_\_  
 Street \_\_\_\_\_  
 City \_\_\_\_\_ State \_\_\_\_\_ Zip \_\_\_\_\_  
 Phone # \_\_\_\_\_ Email \_\_\_\_\_ Invoice # \_\_\_\_\_  
 Model # \_\_\_\_\_ Order # \_\_\_\_\_ Serial # \_\_\_\_\_

The following information is given on a voluntary basis. It will be used for marketing purposes to help us develop better products and services. **Of course, all information is strictly confidential.**

1. How did you learn about us?

Advertisement       Friend       Catalog  
 Card Deck       Website       Other:

2. Which of the following magazines do you subscribe to?

<input type="checkbox"/> Cabinet Maker	<input type="checkbox"/> Popular Mechanics	<input type="checkbox"/> Today's Homeowner
<input type="checkbox"/> Family Handyman	<input type="checkbox"/> Popular Science	<input type="checkbox"/> Wood
<input type="checkbox"/> Hand Loader	<input type="checkbox"/> Popular Woodworking	<input type="checkbox"/> Wooden Boat
<input type="checkbox"/> Handy	<input type="checkbox"/> Practical Homeowner	<input type="checkbox"/> Woodshop News
<input type="checkbox"/> Home Shop Machinist	<input type="checkbox"/> Precision Shooter	<input type="checkbox"/> Woodsmith
<input type="checkbox"/> Journal of Light Cont.	<input type="checkbox"/> Projects in Metal	<input type="checkbox"/> Woodwork
<input type="checkbox"/> Live Steam	<input type="checkbox"/> RC Modeler	<input type="checkbox"/> Woodworker West
<input type="checkbox"/> Model Airplane News	<input type="checkbox"/> Rifle	<input type="checkbox"/> Woodworker's Journal
<input type="checkbox"/> Modeltec	<input type="checkbox"/> Shop Notes	<input type="checkbox"/> Other:
<input type="checkbox"/> Old House Journal	<input type="checkbox"/> Shotgun News	

3. What is your annual household income?

\$20,000-\$29,000       \$30,000-\$39,000       \$40,000-\$49,000  
 \$50,000-\$59,000       \$60,000-\$69,000       \$70,000+

4. What is your age group?

20-29       30-39       40-49  
 50-59       60-69       70+

5. How long have you been a woodworker/metalworker?

0-2 Years       2-8 Years       8-20 Years       20+ Years

6. How many of your machines or tools are Grizzly?

0-2       3-5       6-9       10+

7. Do you think your machine represents a good value?

Yes       No

8. Would you recommend Grizzly Industrial to a friend?

Yes       No

9. Would you allow us to use your name as a reference for Grizzly customers in your area?

**Note:** We never use names more than 3 times.       Yes       No

10. Comments: \_\_\_\_\_  
 \_\_\_\_\_  
 \_\_\_\_\_  
 \_\_\_\_\_

CUT ALONG DOTTED LINE

FOLD ALONG DOTTED LINE

\_\_\_\_\_  
\_\_\_\_\_  
\_\_\_\_\_



Place  
Stamp  
Here



**GRIZZLY INDUSTRIAL, INC.**  
**P.O. BOX 2069**  
**BELLINGHAM, WA 98227-2069**



FOLD ALONG DOTTED LINE

Send a Grizzly Catalog to a friend:

Name \_\_\_\_\_  
Street \_\_\_\_\_  
City \_\_\_\_\_ State \_\_\_\_\_ Zip \_\_\_\_\_

TAPE ALONG EDGES--PLEASE DO NOT STAPLE



# *grizzly.com*

**TOOL WEBSITE**

Buy Direct and Save with Grizzly® – Trusted, Proven and a Great Value!

*Visit Our Website Today And Discover  
Why Grizzly® Is The Industry Leader!*

- SECURE ORDERING
- ORDERS SHIPPED WITHIN 24 HOURS
- E-MAIL RESPONSE WITHIN ONE HOUR

-OR-

Call Today For A **FREE**  
Full Color Catalog

**1-800-523-4777**

